

CONTRACT DOCUMENTS AND SPECIFICATIONS
FOR CONSTRUCTION OF

**CITY OF UNALASKA
PORT LIGHTING UPGRADES**

DPW Project No. 13601

Prepared for:

CITY OF UNALASKA

P.O. Box 610

Unalaska, Alaska 99685

(907) 581-1251



Prepared by:

PND ENGINEERS, INC.

1506 West 36th Avenue

Anchorage, Alaska 99503

(907) 561-1011



ENGINEERS, INC.

ISSUED FOR BID

MARCH 2014

**CITY OF UNALASKA
PORT LIGHTING UPGRADES**

TABLE OF CONTENTS

Part 1 – BIDDING REQUIREMENTS

Section 00030 – Invitation to Bid
Section 00100 – Instructions to Bidders
Section 00300 – Bid Form

Part 2 – CONTRACT REQUIREMENTS

Section 00500 – Standard Form of Agreement
Section 00610 – Performance Bond
Section 00620 – Payment Bond

Part 3 – GENERAL CONDITIONS

General Conditions
Section 00800 – Supplemental Conditions

Part 4 – MINIMUM RATES OF PAY

Minimum Rates of Pay

Part 5 – DRAWINGS

Drawing List

Part 6 – SITE PHOTOS

Site Photos

Part 7 – LIGHT CARGO DOCK EXISTING HIGH MAST LIGHT INFORMATION

Submittal Information

Part 1

BIDDING REQUIREMENTS

Section 00030
INVITATION TO BID

Sealed bids for the City of Unalaska **PORT LIGHTING UPGRADES**, addressed to the City of Unalaska, will be received at the following location:

City of Unalaska

Office of the City Clerk
P.O. Box 610
43 Raven Way
Unalaska, AK 99685
Ph: 907-581-1251 Fax: 907-581-1417

Other pertinent bidding/project information is listed below:

Design Engineer – PND Engineers, Inc. and RSA Engineering, Inc.

Pre-Bid Meeting – March 26, 2014, 2:00 pm (AK), at PND office in Anchorage and City Public Works office in Unalaska, teleconference will be available.

Bids Due – April 15, 2014, 2:00 pm (AK)

Substantial Completion Date – September 1, 2014

Final Completion Date – October 1, 2014

Sealed bids will be received until the local time (Alaska) and date specified above and then will be opened and read. Any bids received after the time and date specified will not be considered.

Work Scope:

The work will include, but not be limited to, furnishing all labor, tools, equipment, and materials and performing all operations in connection with the City of Unalaska **PORT LIGHTING UPGRADES**:

- Remove two (2) existing 150-ft high mast light poles and replace with new 120-ft high mast light poles, anchor rod hardware, and LED fixtures at the UMC City Dock.
- Remove two (2) existing 150-ft high mast light poles and replace with new 120-ft high mast light poles, anchor bolt hardware, and LED fixtures at the UMC USCG Dock.
- Remove and replace the lowering device, mast assembly, and anchor bolt hardware, and remove and replace the fixtures with new LED fixtures on the two (2) existing 120-ft high mast light pole at the Light Cargo Dock. The existing 120-ft high mast light poles are to be reused.
- Remove existing fixtures on fourteen (14) existing light poles and replace with new LED fixtures at the Spit Dock.
- Provide power for and install five (5) Owner-supplied security cameras and associated components to be mounted on four (4) existing light poles at the Spit Dock and Light Cargo Dock.

Project Location:

Port Facilities along Ballyhoo Road; Amaknak Island; Iliuliuk Bay; Dutch Harbor, Alaska

Prevailing Wage Requirements:

Contractor must pay minimum rates of pay as established by the State of Alaska Department of Labor, under AS 36.05.010 and AS 36.10. A copy of the rates effective for the project is included in the Contract Documents.

Bid Requirements:

Each Bid must be submitted on the prescribed form and accompanied by bid security as prescribed in the Instructions to Bidders, payable to the City of Unalaska, Alaska, in an amount not less than 5 (five) percent of the Total Bid amount. The successful Bidder will be required to furnish the necessary

additional bond(s) for the faithful performance of the Contract, as prescribed in the Bidding/Contract Forms.

A site visit by all Bidders is strongly recommended.

The successful Bidder shall hold such Contractors and Business Licenses as required by State Statutes and City of Unalaska Municipal Code Section 9.30.010. The right is reserved to reject any or all Bids, to waive informalities or irregularities in the bidding, and to accept bids that are considered to be in the best interest of the City of Unalaska.

A digital copy of the Bidding Documents may be obtained free of charge from the City of Unalaska website at <http://www.ci.unalaska.ak.us/rfps>. Interested bidders should email or fax their contact information on official letterhead to the City of Unalaska c/o Lori Gregory at lgregory@ci.unalaska.ak.us, Fax (907) 581-2187, or Phone (907) 581-1260. Contact information should include company name, company address, contact name, phone, fax, and email address.

Technical questions shall be directed in writing to Derrick Honrud (PND Engineers, Inc.) at the address shown below:

PND Engineers, Inc.
1506 W. 36th Ave.
Anchorage, AK 99503
Ph: (907) 561-1011 Fax: (907) 563-4220
Attn: **Derrick Honrud, P.E.**
Email: dhonrud@pndengineers.com
Cc: rlund@ci.unalaska.ak.us

Section 00100
INSTRUCTIONS TO BIDDERS

1. Defined Terms.

Terms used in these Instructions to Bidders which are defined in the General Conditions of the Contract Documents have the meanings assigned to them in the General Conditions.

Certain additional terms used in the Bidding Documents have the meanings indicated below which are applicable to both the singular and plural thereof.

- A. Bidder - one who submits a Bid directly to Owner as distinct from a subbidder, who submits a bid to a Bidder.
- B. Bidding Documents - the Bidding Requirements and the proposed Contract Documents (including all Addenda issued prior to receipt of Bids).
- C. Bidding Requirements - the Invitation to Bid, Instructions to Bidders, and Bid Form, plus additional documents that may be submitted with the Bid.
- D. Issuing Office - the City Public Works Department, from which the Bidding Documents are to be issued and where the bidding procedures are to be administered.
- E. Low Bidder - Low Bidder will be determined on the basis of the lowest Amount for the total bid including Owner chosen Additive and/or Deductive Bid Items as described in the Bid Form. Award of the Additive or Deductive Bid Items will be made to the extent that construction funds are available, in such order as may suit the best interest of the Owner. The Deductive and Additive Bid items are not in any specific order and are not listed in order of preference. The Owner reserves the right to select the low bidder on the basis of the Base Bid plus any combination of Additive and/or Deductive Bid items. If the order of the bids is affected, the award will be made on the basis of the Base Bid plus any combination of the Deductive and Additive Bid items.
- F. Successful Bidder - the lowest, qualified, responsible and responsive Bidder to whom the City (on the basis of the City's evaluation as hereinafter provided) makes an Award.

2. Copies of Bidding Documents.

- A. Complete sets of the Bidding Documents for the sum stated in the Invitation to Bid may be obtained from the Issuing Offices.
- B. Complete sets of Bidding Documents must be used in preparing Bids; the City does not assume any responsibility for errors or misinterpretations resulting from the use of incomplete sets of Bidding Documents.
- C. The Drawings bound in the Contract Documents are at a scale indicated by a note or scale bar on the Drawings.
- D. The City, in making copies of Bidding Documents available on the above terms, does so only for the purpose of obtaining Bids for the work and does not confer a license or grant for any other use.

3. **Qualifications of Bidders.**

To demonstrate qualifications to perform the work, each Bidder must be prepared to submit within 5 days after Bid opening upon City's written request, information such as financial data, previous experience, present commitments, subcontractor names and qualifications, and other such data as may be called for below. Each Bid must contain evidence of Bidder's qualification to do business in Alaska. Bidders shall be eligible to obtain a business license from the City of Unalaska.

Nothing indicated herein should prejudice the right of Owner to seek additional pertinent information as provided in the General Conditions.

4. **License Requirements**

Contractors and subcontractors, in order to perform public work in the State of Alaska, are required to hold State of Alaska Contractor's licenses of the class required to perform the specified work. Contractors and subcontractors are also required to hold current Alaska Business Licenses and obtain a City of Unalaska businesses license in order to perform public work in the State of Alaska. Contractor's license and Business License numbers shall be inserted in the appropriate place on the Bid form. Evidence of subcontractor's compliance with the above shall be submitted to the City before starting subcontract work on public work contracts.

5. **Examination of Contract Documents and Site.**

A. It is the responsibility of each Bidder before submitting a Bid:

1. To examine thoroughly the Contract Documents and other related data identified in the Bidding Documents (including "technical data" referred to below);
2. To visit the site to become familiar with and satisfy Bidder as to the general, local, and site conditions that may affect cost, progress, performance, or furnishing of the Work;
3. To consider federal, state, and local Laws and Regulations that may affect cost, progress, performance, or furnishing of the Work;
4. To study and carefully correlate Bidder's knowledge and observations with the Contract Documents and such other related data;
5. To promptly notify the City of all conflicts, errors, ambiguities or discrepancies which Bidder has discovered in or between the Contract Documents and such other related documents;
6. To review applicability of the City of Unalaska sales tax to any purchases of materials or services related to the Work. Refer to Unalaska Code of Ordinances (UCO) Chapter 6.40 for further information.

B. Information and data shown or indicated in the Contract Documents with respect to existing Underground Facilities at or contiguous to the site is based upon information and data furnished to the City by Owners of such Underground Facilities or others, and the City does not assume responsibility for the accuracy or completeness thereof unless it is expressly provided otherwise in the Supplementary Conditions.

- C. Provisions concerning responsibility for the adequacy of data furnished to prospective Bidders on subsurface conditions, other physical conditions and Underground Facilities, and possible changes in the Contract Documents due to differing or unanticipated conditions appear in Article 4 of the General Conditions.
- D. Before submitting a Bid, each Bidder will be responsible to make or obtain such examinations, investigations, explorations, tests, studies, and data concerning conditions (surface, subsurface, and Underground Facilities) at or contiguous to the site or otherwise which may affect cost, progress, performance, or furnishing of the Work or which relate to any aspect of the means, methods, techniques, sequences, or procedures of construction to be employed by Bidder and safety precautions and programs incident thereto or which Bidder deems necessary to determine its Bid for performing and furnishing the Work in accordance with the time, price, and other terms and conditions of the Contract Documents.
- E. On request, the City will provide each Bidder access to the site to conduct such examinations, investigations, explorations, tests and studies as each Bidder deems necessary for submission of a Bid. Bidder shall fill all holes and clean up and restore the site to its former condition upon completion of any such explorations, investigations, test, and studies.
- F. The submission of a Bid will constitute an incontrovertible representation by Bidder that Bidder has complied with every requirement of this Article 5; that, without exception, the Bid is premised upon performing and furnishing the work required by the Contract Documents and applying the specific means, methods, techniques, sequences, or procedures of construction (if any) that may be shown or indicated or expressly required by the Contract Documents; that Bidder has given the Contracting Officer written notice of all conflicts, errors, ambiguities, and discrepancies that Bidder has discovered in the Contract Documents and the written resolution thereof by the City is acceptable to Bidder; and that the Contract Documents are generally sufficient to indicate and convey understanding of all terms and conditions for performing and furnishing the Work.
- G. The provisions of paragraph 5A through 5F above, inclusive, do not apply to asbestos, polychlorinated biphenyl (PCB), petroleum, hazardous waste, or radioactive material covered by the Supplementary Conditions.
- H. Nothing contained in the Bid Documents, any and all attachments thereto, or any and all addenda thereto, shall be interpreted by any party as requiring or allowing the Contractor to do anything that is not in compliance with all applicable codes and regulations, that is less than general standard industry quality, or that results in an unsafe, unstable or dangerous condition.

6. Availability of Lands for Work, Etc.

The lands upon which the work is to be performed, rights-of-way and easements for access thereto, and other lands designated for use by Contractor in performing the work are identified in the Contract Documents. All additional lands and access thereto required for temporary construction facilities, construction equipment, or storage of materials and equipment to be incorporated in the work are to be obtained and paid for by the Successful Bidder. Easements for permanent structures or for permanent changes in existing facilities are to be obtained and paid for by the City unless otherwise provided in the Contract Documents.

7. **Interpretations and Addenda.**

- A. All questions about the meaning or intent of the Bidding Documents are to be directed to the City of Unalaska. Interpretations or clarifications considered necessary by the City in response to such questions will be issued by Addenda mailed or delivered to all parties recorded by the Issuing Office as having received the Bidding Documents. Questions received less than 6 days prior to the date for opening of Bids may not be answered. Only questions answered by formal written Addenda will be binding. Oral and other interpretations or clarifications will be without legal effect.
- B. Addenda may also be issued to modify the Bidding Documents as deemed advisable by the City.

8. **Bid Security.**

- A. Each Bid must be accompanied by Bid security made payable to Owner for 5 percent of Bidder's Total Bid price and in the form of a certified bank check or a Bid Bond on form attached, issued by a Surety meeting the requirements of the General Conditions.
- B. The Bid security of a successful bidder will be retained until such Bidder has executed the Agreement, furnished the required Contract security, and met the other conditions of the Notice of Award, whereupon the Bid security will be returned. If the successful Bidder fails to execute and deliver the Agreement and furnish the required Contract security within 15 days after the Notice of Award, Owner may annul the Notice of Award and the Bid security of that Bidder will be forfeited. The bid security of the Bidders whom Owner believes to have a reasonable chance of receiving the award may be retained by Owner until the earlier of the 7th day after the Effective Date of the agreement or the 60th day after the Bid opening, whereupon Bid security furnished by such Bidders will be returned. Bid security submitted with bids which are not competitive will be returned within 15 days after the Bid opening.

9. **Contract Times.**

The number of days within which, or the dates by which, the work is to be completed and ready for final payment (the Contract Times as defined in Article 1 of the General Conditions) are set forth in the Agreement (or incorporated therein by reference to the attached Bid Form).

10. **Liquidated Damages.**

Provisions for liquidated damages, if any, are set forth in the Agreement.

11. **Bid Form.**

- A. The Bid Form is included with the Bidding Documents.
- B. All blanks on the Bid Form must be completed by printing in black ink or by typewriter.
- C. Bids by corporations must be executed in the corporate name by the president or a vice-president (or other corporate officer accompanied by evidence of authority to sign) and the corporate seal must be affixed and attested by the secretary or an assistant secretary. The corporate address and state of incorporation must be shown below the signature.

- D. Bids by partnerships must be executed in the partnership name and signed by a partner, whose title must appear under the signature and the official address of the partnership must be shown below the signature.
- E. All names must be typed or printed in black ink below the signature.
- F. The Bid shall contain an acknowledgment of receipt of all Addenda (the numbers of which must be filled in on the Bid Form).
- G. The address, telephone, email address, and FAX number for communications regarding the Bid must be shown.
- H. See Article 4 above, for required evidence of authority to conduct business as an out-of-state corporation in Alaska. State Contractor license number, if any, must also be shown.

12. **Submission of Bids.**

- A. Bids shall be submitted not later than the time prescribed, at the place, and in the manner set forth in the Invitation to Bid and shall be enclosed in an opaque sealed envelope, marked with the project title (and, if applicable, the designated portion of the project for which the Bid is submitted) and name and address of Bidder and accompanied by the other required documents. If the Bid is sent through the mail or other delivery system, the sealed envelope shall be enclosed in a separate envelope with the notation "**BID ENCLOSED**" on the face of it.
- B. Only one Bid from any individual, firm, partnership, or corporation, under the same or different names, will be considered. Should it appear to the City that any Bidder is interested in more than one Bid for work contemplated, all Bids in which such Bidder is interested will be rejected.
- C. Attachments.

Bidder shall complete and submit the following forms with its Bid:

Bid Form
Addenda Acknowledgment
Alaska Bid Bond (5% of Bid)
Alaska Business and Contractor's License

13. **Modifications and Withdrawal of Bids.**

- A. Prior to the time and date designated for receipt of Bids, any Bid submitted may be withdrawn by notice to the party receiving Bids at the place designated for receipt of Bids. Such notice shall be in writing over the signature of the Bidder or by facsimile. If by facsimile, the modification received shall be over the signature of the Bidder and shall be received before the date and time set for receipt of Bids. Facsimile messages shall be worded as to not reveal the amount of the original or modified Bid. Facsimile telephone number is:

City of Unalaska (907) 581-1417

Bid modifications must be sent to the office to which the original proposal is delivered or sent.

- B. If, within 24 hours after Bids are opened, any Bidder files a duly signed, written notice with the City and promptly thereafter demonstrates to the reasonable satisfaction of the City that there was a material and substantial mistake in the preparation of its Bid, that Bidder may withdraw its Bid. Thereafter, that Bidder will be disqualified from further consideration on the Work to be provided under the Contract Documents.

14. **Opening of Bids.**

Bids will be opened and read aloud publicly at the place where Bids are to be submitted.

15. **Bids to Remain Subject to Acceptance.**

All Bids will remain subject to acceptance for 60 days after the day of the Bid opening, but the City may, in its sole discretion, release any Bid and return the Bid security prior to that date.

16. **Award of Contract.**

- A. The City reserves the right to reject any or all Bids, including without limitation the rights to reject any or all nonconforming, nonresponsive, unbalanced or conditional Bids, and to reject the Bid of any Bidder if the City believes that it would not be in the best interest of the Project to make an award to that Bidder, whether because the Bid is not responsive or the Bidder is unqualified or of doubtful financial ability or fails to meet any other pertinent standard or criteria established by Owner. The City also reserves the right to waive all informalities not involving price, time, or changes in the Work and to negotiate Contract terms with the successful Bidder. Discrepancies in the multiplication of units of work and unit prices will be resolved in favor of the unit prices. Discrepancies between the indicated sum of any column of figures and the correct sum thereof will be resolved in favor of the correct sum. Discrepancies between words and figures will be resolved in favor of the words.
- B. In evaluating Bids, the City will consider the qualifications of Bidders, whether or not the Bids comply with the prescribed requirements, and such alternates, unit prices, and other data, as may be requested in the Bid Form or prior to the Notice of Award.
- C. The City may consider the qualifications and experience of subcontractors, suppliers, and other persons and organizations proposed for those portions of the Work as to which the identity of subcontractors, suppliers, and other persons and organizations must be submitted as provided in the Supplementary Conditions. The City also may consider the operating costs, maintenance requirements, performance data, and guarantees of major items of materials and equipment proposed for incorporation in the Work when such data are required to be submitted prior to the Notice of Award.
- D. The City may conduct such investigations as the City deems necessary to assist in the evaluation of any Bid and to establish the responsibility, qualifications, and financial ability of Bidders, proposed subcontractors, suppliers, and other persons and organizations to execute the work in accordance with the Contract Documents to the City's satisfaction within the prescribed time.
- E. If, at the time this Contract is to be awarded, the total of the lowest acceptable Bid exceeds the funds then estimated by the City as available, the City may reject all Bids or take such other action as best serves the City's interests.

- F. If the Contract is to be awarded, it will be awarded to lowest responsive, responsible Bidder as stated in Section 00100 Instructions To Bidders, whose evaluation by the City indicates to the City that the award will be in the best interests of the Project.
- G. In the event of failure of the lowest responsive, responsible Bidder to sign the Contract and provide an acceptable Performance Bond, Payment Bond, and insurance certificate(s), the Owner may award the Contract to the next lowest responsive, responsible Bidder. Such award, if made, will be made within 60 days after the opening of Proposals.
- H. An Additive or Deductive Bid Item is an amount proposed by Bidders and stated on the Bid Form for certain construction activities defined in the Bidding Requirements that may be added to or deducted from the Base Bid amount if the Owner decides to accept a corresponding change in either the amount of construction to be completed, or in the products, materials, equipment, systems or installation methods described in the Contract Documents.
- I. Award of the Additive or Deductive Bid Items will be made to the extent that construction funds are available, in such order as may suit the best interest of the Owner. The Deductive and Additive Bid items are not in any specific order and are not listed in order of preference. The Owner reserves the right to select the Base Bid plus any combination of Additive and/or Deductive Bid items. If the order of the bids is affected, the award will be made on the basis of the Base Bid plus any combination of Additive or Deductive Bid items that the Owner selects at their option.

17. **Contract Security.**

Article 5 of the General Conditions sets forth Owner's requirements as to Performance and Payment Bonds. When the successful Bidder delivers the executed Agreement to Owner, it must be accompanied by the required Performance and Payment Bonds.

18. **Signing of Agreement.**

When the City gives a Notice of Award to the successful Bidder, it will be accompanied by the required number of unsigned counterparts of the Agreement, with all other written Contract Documents attached. Within 10 days thereafter, contractor shall sign and deliver the required number of counterparts of the Agreement and attached documents to the City with the required Bonds. Within 10 days thereafter, the City shall deliver one fully signed counterpart to Contractor.

19. **State Required Wage Rates.**

All workers shall be paid prevailing wage rates as described in the State of Alaska LABORERS' AND MECHANICS' MINIMUM RATES OF PAY, Title 36, Public Contracts, AS 36.05 & AS 35.10 Wage and Hour Administration Pamphlet No. 600 – Latest revision.

20. **Construction Coordination**

Construction activities must be coordinated with the normal operation of the Port facilities/docks being affected. The Contractor shall develop a plan for review to coordinate and schedule work with these groups to minimize impacts to their operation. This will require weekly construction schedules and meetings or other means of communication so shipping operations can be coordinated.

The Contractor shall coordinate staging, storage, and construction activities with the City. Staging areas allocated to the Contractor for each site are shown on the project drawings. The Contractor must consider if the size and location of the designated staging areas are adequate, and if not, should consider lease of additional areas. This must be considered in the Bid cost.

The City's intent is to work with the Contractor to provide prompt decisions and minimize the impact of delays. The Contractor is asked to work with the City and its Contracting Officer to resolve all issues and build a successful project. The Port will be the project contact for communication of dock logistics.

When certain vessels are in Port (such as container ships, fuel barges, foreign flag vessels, ferries, or passenger ships), access to the secure areas of the Port facilities (including the staging area) will be restricted unless the Contractor possesses the required Transportation Worker Identification Credential (TWIC) cards.

NOTE TO BIDDER: Use BLACK ink or typewriter for completing this Bid Form.

**Section 00300
BID FORM**

To: **City of Unalaska, Department of Public Works**

Address: **P.O. Box 610, Unalaska, Alaska 99685**

Project Identification: **City of Unalaska PORT LIGHTING UPGRADES**

DEFINITIONS

The terms used in this Bid which are defined in the General Conditions and Instructions to Bidders included as part of the Contract Documents are used with the same meaning in this Bid.

BIDDERS DECLARATION AND UNDERSTANDING

This Bid is genuine and not made in the interest of or on behalf of any undisclosed person, firm, or corporation and is not submitted in conformity with any agreement or rules of any group, association, organization, or corporation; Bidder has not directly or indirectly induced or solicited any other Bidder to submit a false or sham Bid; Bidder has not solicited or induced any person, firm, or corporation to refrain from bidding; and Bidder has not sought by collusion to obtain for itself any advantage over any other Bidder or over the City.

In submitting this Bid, Bidder represents, as more fully set forth in the Agreement, that Bidder has examined copies of all the Bidding Documents.

Bidder has familiarized itself with the nature and extent of the Contract Documents, work, site, locality, general nature of work to be performed by Owner or others at the site that relates to work for which this Bid is submitted as indicated in the Contract Documents, and all local conditions and all federal, state, and local Laws and Regulations that in any manner may affect cost, progress, performance, or furnishing of the work.

Bidder has reviewed and checked all information and data shown or indicated in the Contract Documents with respect to existing Underground Facilities at or contiguous to the site and assumes responsibility for the accurate location of said Underground Facilities. No additional examinations, investigations, explorations, tests, reports, or similar information or data in respect of said Underground Facilities are or will be required by Bidder in order to perform and furnish the work at the Contract Price, within the Contract Time, and in accordance with the other terms and conditions of the Contract Documents, including specifically the provisions of paragraph 4.3 of the General Conditions.

Bidder has correlated information known to Bidder and the results of all such observations, examinations, investigations, explorations, tests, and studies with the Contract Documents.

Bidder has given the City written notice of all conflicts, errors, ambiguities or discrepancies that it has discovered in the Contract Documents and the written resolution thereof by the City is acceptable to Bidder, and the Contract Documents are generally sufficient to indicate and convey understanding of all terms and conditions for performing and furnishing the work for which this Bid is submitted.

CONTRACT EXECUTION AND BONDS

The undersigned Bidder proposes and agrees, if this Bid is accepted, to enter into an agreement with the City in the form included in the Contract Documents to perform and furnish all work as specified or

indicated in the Contract Documents for the Contract price and within the Contract Time indicated in this Bid and in accordance with the other terms and conditions of the Contract Documents.

Bidder accepts all of the terms and conditions of the Invitation to Bid and Instructions to Bidders, including without limitation those dealing with the disposition of Bid security. This Bid will remain subject to acceptance for 60 days after the day of Bid opening. Bidder will sign and deliver the required number of counterparts of the Agreement with the Bonds and City of Unalaska business license and other documents required by the Bidding Requirements within 10 days after the date of Owner's Notice of Award.

CERTIFICATE OF INSURANCE

Bidder agrees to furnish the City, before commencing any Physical Work related to this Contract and as required elsewhere, the certificates of insurance as specified in these Documents.

Bidder further agrees that the amount stated herein includes specific consideration for the insurance coverages, including contractual liability, specified in the Contract Documents.

CONTRACT COMPLETION TIME

Bidder agrees that the work will be completed and ready for final payment in accordance with the number of calendar days or completion date indicated in the Agreement.

LIQUIDATED DAMAGES

Bidder accepts the provisions of the Agreement as to liquidated damages in the event of failure to complete the work within the times specified in the Agreement.

ADDENDA

The Bidder hereby acknowledges that it has received Addenda No's _____, _____, _____, _____, _____, _____ (Bidder shall insert No. of each Addendum received) and agrees that all addenda issued are hereby made part of the Contract Documents, and the Bidder further agrees that its Bid(s) includes all impacts resulting from said addenda.

SALES AND USE TAXES

The Bidder agrees that all sales and use taxes are included in the stated bid prices for the work, unless provision is made herein for the Bidder to separately itemize the estimated amount of sales tax.

SUBCONTRACTORS

The Bidder further agrees that if the bid is the apparent low bid, he shall submit, within 5 days after the bid opening, a listing of subcontracting firms or businesses that will be awarded subcontracts for work in excess of \$5,000 and a copy of the City of Unalaska business license for the Contractor and each Subcontractor.

BID TABULATION AND SUMMARY

The Bidder further proposes to accept, as full payment for work proposed herein, the amount computed under provisions of the Contract Documents and based on the following Bid amounts, it being expressly understood that the unit quantities of work shown on the plans is independent of the exact quantities involved. The Bidder agrees that the bid amount represent(s) a true measure of the labor and materials

required to furnish, install, or provide the item of Work, including all allowances for overhead and profit. The amount shall be shown in both words and figures. In case of a discrepancy, the amount shown in words shall govern.

Bidder agrees to perform all of the work described in the Documents including the specifications, special provisions, and as generally shown on the plans for the prices stated in the Bid Schedules. Bidder understands that the Owner reserves the right to reject any or all bids and to waive any informalities in the bidding. Bidder understands that the Owner reserves the right to pick and choose what bid items will be constructed as part of this work, recognizing that Mobilization and Demobilization will be common to the remaining items of Work.

**City of Unalaska
PORT LIGHTING UPGRADES**

BIDDER

If the Bidder is awarded a construction Contract on this Proposal, the surety who provides the Performance Bond and Payment Bond will be _____

_____ whose address is _____

_____, _____,

Street

City

_____.

State

Zip

BIDDER

An Individual

By

_____ (SEAL)

(Individual's name)

doing business as

Business

address: _____

Phone No.: _____

Fax No.: _____

Email address: _____

A Partnership

By _____ (SEAL)
(Firm name)

(general partner)

Business address: _____

Phone No.: _____

Fax No.: _____

Email address: _____

A Corporation

By _____
(Corporation name)

(state of incorporation)

By _____
(name of person authorized to sign)

(Title)

(Corporate Seal)

Attest _____
(Secretary)

Business address: _____

Phone No.: _____

Fax No.: _____

Email address: _____

A Joint Venture

By _____
(Name)

(Address)

By _____
(Name)

(Address)

Phone Number and Address for receipt of official communications

Business address: _____

Phone No.: _____

Fax No.: _____

Email address: _____

(Each joint venturer must sign. The manner of signing for each individual, partnership, and corporation that is a party to the joint venture should be in the manner indicated above.)

SUBMITTED on _____, 20__.

BID PROPOSAL

In accordance with the Invitation for Bids and all Terms, Conditions, Plans and Specifications related thereto, I propose to furnish materials and perform construction for the following Lump Sum (LS) or Unit (per unit) prices:

BASE BID ITEMS:

1. Site Mobilization and Demobilization: Work shall consist of transporting, mobilizing and demobilizing all materials, construction equipment, and personnel necessary to complete this project as detailed in the Plans.

_____ LS \$ _____ LS

(Lump Sum In Words)

2. UMC City Dock Lighting Upgrades: Work shall consist of providing all materials, labor, equipment, incidentals, traffic control, and other work necessary to remove two (2) existing 150-ft high mast light poles and replace with new 120-ft high mast light poles, anchor rod hardware, and LED fixtures as detailed in the Plans.

_____ LS \$ _____ LS

(Lump Sum In Words)

3. UMC USCG Dock Lighting Upgrades: Work shall consist of providing all materials, labor, equipment, incidentals, traffic control, and other work necessary to remove two (2) existing 150-ft high mast light poles and replace with new 120-ft high mast light poles, anchor bolt hardware, and LED fixtures as detailed in the Plans.

_____ LS \$ _____ LS

(Lump Sum In Words)

4. Light Cargo Dock Lighting Upgrades: Work shall consist of providing all materials, labor, equipment, incidentals, traffic control, and other work necessary to replace the lowering device, mast assembly, and anchor bolt hardware, and replace the fixtures with new LED fixtures on the two (2) existing 120-ft high mast light poles as detailed in the Plans. (For this Base Bid Item, the existing 120-ft high mast light poles are to be reused.)

_____ LS \$ _____ LS

(Lump Sum In Words)

5. Spit Dock Lighting Upgrades: Work shall consist of providing all materials, labor, equipment, incidentals, traffic control, and other work necessary to remove the existing light fixtures and replace with new LED fixtures at fourteen (14) existing light poles as detailed in the Plans.

_____ LS \$ _____ LS

(Lump Sum In Words)

6. Power for Security Cameras: Work shall consist of providing all materials, labor, equipment, incidentals, traffic control, and other work necessary to provide power for and mount five (5) Owner-supplied security cameras and associated components on four (4) existing light poles at the Spit Dock and Light Cargo Dock as detailed in the Plans.

_____ LS \$ _____ LS
 (Lump Sum In Words)

7. Site Restoration, Cleanup, & As-Built Drawings: Work shall consist of providing all materials, labor, equipment and incidentals necessary to clean-up site and restore all used areas to a neat and clean condition as determined by the City's Construction Engineer and provide red-lined as-built drawings for the project. Excess material shall be disposed of as directed by the City and in accordance with applicable governmental regulations. The bid for this item shall not be less than five thousand dollars (\$5,000).

_____ LS \$ _____ LS
 (Lump Sum In Words)

BASE BID TOTAL:

_____ LS \$ _____ LS
 (Lump Sum In Words)

ADDITIVE ALTERNATE BID ITEMS:

1. New 120-ft High Mast Light Poles at Light Cargo Dock: Work shall consist of providing all materials, labor, equipment, incidentals, and other work necessary to remove two (2) existing 120-ft high mast light poles and replace with new 120-ft high mast light poles, anchor bolt hardware, LED fixtures, and FAA warning lights as detailed in the Plans. (This Additive Alternate Bid Item corresponds to Base Bid Item #4 above. The price for this Additive Alternate Bid Item is the increase or decrease from Base Bid Item #4.)

_____ LS \$ _____ LS
 (Lump Sum In Words)

Bidding Company: _____

Name (Printed): _____

Signature: _____ Date: _____

Contractors License No. _____ Business License No. _____

BID BOND

KNOW ALL MEN BY THESE PRESENTS: that

(Name of Contractor)

(Address of Contractor)

as Principal, hereinafter called Principal, and

(Name of Surety)

(Address of Surety)

a corporation duly organized under the laws of the State of Alaska as Surety, hereinafter called Surety, are held and firmly bound unto

City of Unalaska _____
(Name of Owner)

P.O. Box 610, Unalaska, Alaska 99685 _____
(Address of Owner)

as Obligee, hereinafter called Obligee, in the sum of _____ Dollars, (\$ _____) for the payment of which sum well and truly to be made, the said Principal and the said Surety, bind ourselves, our heirs, executors, administrators, successors and assigns, jointly and severally, firmly by these presents.

WHEREAS, the Principal has submitted a bid for the City of Unalaska **PORT LIGHTING UPGRADES** located in Unalaska, Alaska.

NOW THEREFORE, if the Obligee shall accept the bid of the Principal and the Principal shall enter into a Contract with the Obligee in accordance with the terms of such bid, and give such bond or bonds as may be specified in the bidding or Contract Documents with good and sufficient surety for the faithful performance of such Contract and for the prompt payment of labor and material furnished in the prosecution thereof, or in the event of the failure of the Principal to enter such Contract and give such bond or bonds, if the Principal shall pay to the Obligee the difference not to exceed the penalty hereof between the amount specified in said bid and such larger amount for which the Obligee may in good faith contract with another party to perform the Work covered by said bid, then this obligation shall be null and void, otherwise to remain in full force and effect.

Signed and Sealed this _____ day of _____, 2014

(Principal) Seal

(Witness)

(Title) Seal

(Surety) Seal

(Witness)

(Title) Seal

Part 2

CONTRACT FORMS

Section 00500
STANDARD FORM OF AGREEMENT
BETWEEN THE OWNER AND CONTRACTOR

THIS AGREEMENT is dated as of the _____ day of _____ in the year 2014, by and between the **City of Unalaska** (hereinafter called OWNER) and _____ (hereinafter called "CONTRACTOR").

OWNER and CONTRACTOR, in consideration of the mutual covenants hereinafter set forth, agree as follows:

Article 1. WORK

CONTRACTOR shall complete all work as specified or indicated in the Contract Documents. The work is generally described as follows:

The work will include, but not be limited to, furnishing all labor, tools, equipment, and materials and performing all operations in connection with the **City of Unalaska PORT LIGHTING UPGRADES**.

- Project Location: Port Facilities along Ballyhoo Road; Amaknak Island; Iliuliuk Bay; Dutch Harbor, AK
- Owner: City of Unalaska

The Contract Documents which comprise the entire agreement between OWNER and CONTRACTOR concerning the WORK consists of the following:

- Agreement
- Invitation to Bid
- Instructions to Bidders
- Bid Forms
- Addenda numbers _____ to _____, inclusive
- Performance Bond
- Payment Bond
- General Conditions
- Supplementary Conditions
- Drawings and Specifications
- Change Orders which may be delivered or issued after Effective Date of the Agreement and not attached hereto
- State of Alaska LABORERS' & MECHANICS' MINIMUM RATES OF PAY, Pamphlet 600, Issue _____, Effective Date _____

Article 2. CONTRACT TIME

- 2.1 For the Base Bid Items and all awarded Additive Bid Items, the **Substantial Completion date shall be September 1, 2014** and the **Final Completion date shall be October 1, 2014**.
- 2.2 **Liquidated Damages.** The OWNER and CONTRACTOR recognize that time is of the essence of this Agreement and that the OWNER will suffer financial loss if the work is not completed within the times specified above, plus any extensions thereof allowed in accordance with Article 11 of the General Conditions. These damages include, the potential loss of direct revenue from use of the Project Site, potential indirect loss of revenue resulting from vessels deciding to use other facilities, general inconvenience to the public and similar difficult to quantify elements of damage. They also recognize the delays, expense, and difficulties involved in proving in a legal

or arbitration preceding the actual loss suffered by the OWNER if the work is not substantially completed on time. Accordingly, instead of requiring any such proof, the OWNER and CONTRACTOR agree that as liquidated damages for delay (but not as a penalty) CONTRACTOR shall pay the OWNER **Five Hundred Dollars (\$500.00) for each day** that expires after the time specified above for **Substantial Completion** and **One Thousand Dollars (\$1,000.00) for each day** that expires after the time specified above for **Final Completion** and readiness for final payment. Should Substantial Completion not be accomplished before the specified Final Completion date, then the combined liquidated damages shall be **One Thousand Dollars (\$1,000.00) for each day**.

Article 3. CONTRACT PRICE

- 3.1 The OWNER shall pay CONTRACTOR for completion of the work in accordance with the Contract Documents an amount equal to sum of the established unit prices for each separately identified item of unit price work multiplied by the measured quantity of actual items installed plus the sum of the lump sum prices for each separately identified and selected bid item (herein referred to as the "Contract Sum").
- 3.2 The Contract Sum is based upon the Proposal Items which are set forth in the Contract Documents and which are hereby accepted by the OWNER.
- 3.3 The Contract Sum for the Base Bid and Awarded Additive Alternate Items is \$_____.

Article 4. PAYMENT PROCEDURES

CONTRACTOR shall submit Applications for Payment in accordance with Article 13 of the General Conditions. Applications for Payment will be processed by the OWNER as provided in the General Conditions.

- 4.1. Progress Payments. The OWNER shall make progress payments on account of the Contract Price on the basis of CONTRACTOR's Applications for Payment on or about a day of the month mutually agreeable to the OWNER and CONTRACTOR as agreed to at the preconstruction conference. All progress payments will be on the basis of the progress of the work measured by the actual installed quantity of items, plus allowances for stockpiled materials.
 - 4.1.1. Prior to Substantial Completion, progress payments will be made in an amount equal to the percentage indicated below, but, in each case, less the aggregate of payments previously made and less such amounts as the OWNER shall determine, or the OWNER may withhold, in accordance with Article 13 (paragraph 13.8) of the General Conditions and the Supplemental Conditions.
 - a. Ninety percent of work completed.
 - b. Once 50 percent of the work is complete as determined by the OWNER, and if the character and progress of the work have been satisfactory to the OWNER, the OWNER, may determine that, as long as the character and progress of the work remain satisfactory to them, there will be no additional retainage on account of work completed; in which case, the remaining progress payments prior to - Substantial Completion will be in an amount equal to 100 percent of the work completed.

4.1.2. Upon Substantial Completion, in an amount sufficient to increase total payments to CONTRACTOR to 95 percent of the Contract Price, less such amounts as the OWNER shall determine, or the OWNER may withhold, in accordance with Article 13 of the General Conditions.

4.2. Final Payment. Upon final completion and acceptance of the work in accordance with the General Conditions; Affidavit of Payment of Debts and Claims; Affidavit of Release of Liens; and Receipt of Consent of Surety Company to Final Payment, the OWNER shall pay the remainder of the Contract Price as provided in said Article 13.

4.2.1 Deductions. The City may deduct from the amount of any payment made to Contractor any sums owed to City by Contractor including, but not limited to, past due sales tax, port and harbor fees, property tax, or rent. Before making any such deduction the City shall have provided Contractor written notice of the amount claimed by City to be due and owing from Contractor.

Article 5. INTEREST ON RETAINAGE

All retainage shall bear interest at the rate required by AS 36.90.250, if applicable.

Article 6. CONTRACTOR'S REPRESENTATIONS

In order to induce the OWNER to enter into this agreement, CONTRACTOR makes the following representations:

- 6.1. CONTRACTOR has familiarized itself with the nature and extent of the Contract Documents, work, site, locality, and all local conditions and Laws and Regulations that in any manner may affect cost, progress, performance, or furnishing of the work.
- 6.2. CONTRACTOR has obtained and carefully studied (or assumes responsibility for obtaining and carefully studying) all such examinations, investigations, explorations, tests, reports, and studies which pertain to the subsurface or physical conditions at or contiguous to the site or which otherwise may affect the cost, progress, performance, or furnishing of the work as CONTRACTOR considers necessary for the performance or furnishing of the work at the Contract Price, within the Contract Time, and in accordance with the other terms and conditions of the Contract Documents, including specifically the provisions of paragraph 4.2 of the General Conditions; and no additional examinations, investigations, explorations, tests, reports, studies, or similar information or data are or will be required by CONTRACTOR for such purposes.
- 6.3. CONTRACTOR has reviewed and checked all information and data shown or indicated on the Contract Documents with respect to existing Underground Facilities at or contiguous to the site and assumes responsibility for the accurate location of said Underground Facilities. No additional examinations, investigations, explorations, tests, reports, studies, or similar information or data in respect of said Underground Facilities are or will be required by CONTRACTOR in order to perform and furnish the work at the Contract Price, within the Contract Time, and in accordance with the other terms and conditions of the Contract Documents, including specifically the provisions of paragraph 4.4 of the General Conditions.
- 6.4. CONTRACTOR has correlated the results of all such observations, examinations, investigations, explorations, tests, reports, and studies with the terms and conditions of the Contract Documents.
- 6.5. CONTRACTOR has given the OWNER written notice of all conflicts, errors, or discrepancies that it has discovered in the Contract Documents and the written resolution thereof by the OWNER is acceptable to CONTRACTOR.

Article 7. MISCELLANEOUS

- 7.1. Terms used in this Agreement which are defined in Article 1 of the General Conditions will have the meanings indicated in the General Conditions.
- 7.2. The CONTRACTOR shall submit the Performance Bond, Labor and Material Payment Bonds, and Certification of Insurance and City of Unalaska business licenses and all Subcontractor City of Unalaska business licenses as required by the Contract Documents, prior to commencement of the Work. The Performance and Material Payment Bonds shall be in the amount of 100% of the contract bid price.
- 7.3. No assignment by a party hereto of any rights under or interests in the Contract Documents will be binding on another party hereto without the written consent of the party sought to be bound; and specifically but without limitation monies that may become due and monies that are due may not be assigned without such consent (except to the extent that the effect of this restriction may be limited by law), and unless specifically stated to the contrary in any written consent to an assignment no assignment will release or discharge the assignor from any duty or responsibility under the Contract Documents.
- 7.4. OWNER and CONTRACTOR each binds itself, its partners, successors, assigns, and legal representatives to the other party hereto, its partners, successors, assigns, and legal representatives in respect of all covenants, agreements, and obligations contained in the Contract Documents.

IN WITNESS WHEREOF, The OWNER and CONTRACTOR have signed all counterparts of this Agreement. All portions of the Contract Documents have been signed or identified by the OWNER and - CONTRACTOR.

This Agreement will be effective on _____, 2014.

CITY OF UNALASKA

CONTRACTOR _____

By _____
Chris Hladick, City Manager

By _____

(CORPORATE SEAL)

(CORPORATE SEAL)

Attest _____
City Clerk

Attest _____

Address for giving notices:
P.O. Box 610
Unalaska, Alaska 99685

Address for giving notices:

Section 00610
PERFORMANCE BOND

KNOW ALL MEN BY THESE PRESENTS: that

(Name of Contractor)

(Address of Contractor)

as Principal, hereinafter called Principal, and

(Name of Surety)

(Address of Surety)

as Surety, hereinafter called Surety, are held and firmly bound unto

City of Unalaska
(Name of Owner)

PO Box 610, Unalaska, Alaska 99685
(Address of Owner)

as Obligee, hereinafter called Obligee, in the sum of _____

_____ Dollars, (\$ _____) for the payment of which sum well and truly to be made, the said Principal and the said Surety, bind ourselves, our heirs, executors, administrators, successors and assigns, jointly and severally, firmly by these presents.

WHEREAS, the Contractor has a written agreement dated _____ day of _____, 20 ____, entered into a Contract with Owner for the

City of Unalaska
PORT LIGHTING UPGRADES

in accordance with the Specifications prepared by the **PND Engineers, Inc.**, which Contract is by reference made a part hereof, and is hereinafter referred to as the Contract.

NOW THEREFORE, THE CONDITION OF THIS OBLIGATION is such that, if Contractor shall promptly and faithfully perform said Contract, then this obligation shall be null and void; otherwise it shall remain in full force and effect.

The Surety hereby waives notice of any alteration or extension of time made by the Owner.

Whenever Contractor shall be, and declared by Owner to be in default under the Contract, the Owner having performed Owner's obligations thereunder, the Surety may promptly remedy the default, or shall promptly

1) Complete the Contract in accordance with its terms and conditions, or

2) Obtain a bid or bids for completing the Contract in accordance with its terms and conditions, and upon determination by Surety of the lowest responsible bidder, or, if the Owner elects, upon determination by the Owner and the Surety jointly of the lowest responsible bidder, arrange for a contract between such bidder and Owner, and make available as the Work progresses (even though there should be a default or a succession of defaults under the contract or contracts completion arranged under this paragraph) sufficient funds to pay the cost of completion less the balance of the contract price; but not exceeding, including other costs and damages for which the Surety may be liable hereunder, the amount set forth in the first paragraph hereof. The term "balance of the Contract price", as used in this paragraph, shall mean the total amount payable by Owner to the Contractor under the Contract and any amendments thereto, less the amount properly paid by Owner to Contractor.

Any suit under this bond must be instituted before the expiration of six (6) years from the date on which final payment under the Contract falls due.

No right of action shall accrue on this bond to or for the use of any person or corporation other than the Owner named herein or the heirs, executors, administrators, or successors of the Owner.

Signed and Sealed this _____ day of _____ 20____.

(Principal) Seal

(Witness)

(Title) Seal

(Surety) Seal

(Witness)

(Title) Seal

**Section 00620
PAYMENT BOND**

KNOW ALL MEN BY THESE PRESENTS,

That _____ as Contractor, and
_____ as Surety, are held and firmly bound unto
City of Unalaska hereinafter called "OWNER", in the sum of _____ dollars, for the
payment of which sum, well and truly made, we bind ourselves, our heirs, executors, administrators,
successors, and assigns, jointly and severally, firmly by these presents.

WHEREAS, said CONTRACTOR has been awarded and is about to enter into the annexed Agreement
with said OWNER to perform the WORK as specified or indicated in the Contract Documents entitled

City of Unalaska
PORT LIGHTING UPGRADES

NOW THEREFORE, if said CONTRACTOR, or subcontractor, fails to pay for any materials, equipment,
or other supplies, or for rental of same, used in connection with the performance of work contracted to be
done, or for amounts due under applicable State law for any work or labor thereon, said Surety will pay
for the same in an amount not exceeding the sum specified above, and, in the event suit is brought upon
this bond, a reasonable attorney's fee to be fixed by the court. This bond shall inure to the benefit of any
persons, companies, or corporations entitled to file claims under applicable State law.

PROVIDED, that any alterations in the WORK to be done or the materials to be furnished, or changes in
the time of completion, which may be made pursuant to the terms of said Contract Documents, shall not
in any way release said CONTRACTOR or said surety thereunder, nor shall any extensions of time
granted under the provisions of said Contract Documents release either said CONTRACTOR or said
Surety thereunder, nor shall any extensions of time granted under the provisions of said Contract
Documents release either said CONTRACTOR or said Surety, and notice of such alterations or
extensions of the Agreement is hereby waived by said Surety.

SIGNED AND SEALED, this _____ day of _____, 20____.

(SEAL)

(CONTRACTOR)

(Surety)

By: _____
(Signature)

By: _____
(Signature)

(SEAL AND NOTARIAL ACKNOWLEDGMENT OF SURETY)

Part 3
GENERAL CONDITIONS

ARTICLE 1 - DEFINITIONS

ARTICLE 2 -AUTHORITIES AND LIMITATIONS

- 2.1 Authorities and Limitations
- 2.2 Evaluations by Contracting Officer
- 2.3 Means and Methods
- 2.4 Visits to Site

**ARTICLE 3 - CONTRACT DOCUMENTS:
INTENT, AMENDING, REUSE**

- 3.1 Incomplete Contract Documents
- 3.2 Copies of Contract Documents
- 3.3 Scope of Work
- 3.4 Intent of Contract Documents
- 3.5 Discrepancy in Contract Documents
- 3.6 Clarifications and Interpretations
- 3.7 Reuse of Documents

**ARTICLE 4 - LANDS AND PHYSICAL CONDI-
TIONS**

- 4.1 Availability of Lands
- 4.2 Visit to Site
- 4.3 Explorations and Reports
- 4.4 Utilities
- 4.5 Damaged Utilities
- 4.6 Utilities Not Shown or Indicated
- 4.7 Survey Control

**ARTICLE 5 - BONDS AND INSURANCE
AND INDEMNIFICATION**

- 5.1 Delivery of Bonds
- 5.2 Bonds
- 5.3 Replacement of Bond and Surety
- 5.4 Insurance Requirements
- 5.5 Indemnification

**ARTICLE 6 - CONTRACTOR'S RESPONSIBILI-
TIES**

- 6.1 Supervision of Work
- 6.2 Superintendence by CONTRACTOR
- 6.3 Character of Workers
- 6.4 CONTRACTOR to Furnish
- 6.5 Materials and Equipment
- 6.6 Anticipated Schedules
- 6.7 Finalizing Schedules
- 6.8 Adjusting Schedules
- 6.9 Substitutes of "Or-Equal" Items
- 6.10 Substitute Means and Methods
- 6.11 Evaluation of Substitution
- 6.12 Dividing the Work
- 6.13 Subcontractors
- 6.14 Use of Premises

GENERAL CONDITIONS

- 6.15 Structural Loading
- 6.16 Record Documents
- 6.17 Safety and Protection
- 6.18 Safety Representative
- 6.19 Emergencies
- 6.20 Shop Drawings and Samples
- 6.21 Shop Drawings and Sample Review
- 6.22 Maintenance During Construction
- 6.23 Continuing the Work
- 6.24 Consent to Assignment
- 6.25 Use of Explosives
- 6.26 CONTRACTOR's Records

ARTICLE 7 - LAWS AND REGULATIONS

- 7.1 Laws to be Observed
- 7.2 Permits, Licenses, and Taxes
- 7.3 Patented Devices, Materials and Processes
- 7.4 Compliance of Specifications and Drawings
- 7.5 Accident Prevention
- 7.6 Sanitary Provisions
- 7.7 Business Registration
- 7.8 Professional Registration and Certification
- 7.9 Local Building Codes
- 7.10 Air Quality Control
- 7.11 Archaeological or Paleontological Discoveries
- 7.12 Alaska Forest Products
- 7.13 Preferential Employment
- 7.14 Wages and Hours of Labor
- 7.15 Overtime Work Hours and Compensation
- 7.16 Covenant Against Contingent Fees
- 7.17 Officials Not to Benefit
- 7.18 Personal Liability of Public Officials

ARTICLE 8 - OTHER WORK

- 8.1 Related Work at Site
- 8.2 Access, Cutting, and Patching
- 8.3 Defective Work by Others
- 8.4 Coordination

ARTICLE 9 - CHANGES

- 9.1 CITY's Right to Change
- 9.2 Authorization of Changes within the General Scope
- 9.3 Directives
- 9.4 Change Order
- 9.5 Shop Drawing Variations
- 9.6 Changes Outside the General Scope;
Supplemental Agreement
- 9.7 Unauthorized Work
- 9.8 Notification of Surety
- 9.9 Differing Site Conditions

ARTICLE 10 - CONTRACT PRICE; COMPUTATION AND CHANGE

- 10.1 Contract Price
- 10.2 Claim for Price Change
- 10.3 Change Order Price Determination
- 10.4 Cost of the Work
- 10.5 Excluded Costs
- 10.6 CONTRACTOR's Fee
- 10.7 Cost Breakdown
- 10.8 Cash Allowances
- 10.9 Unit Price Work
- 10.10 Determinations for Unit Prices

ARTICLE 11 - CONTRACT TIME; COMPUTATION AND CHANGE

- 11.1 Commencement of Contract Time; Notice to Proceed
- 11.2 Starting the Work
- 11.3 Computation of Contract Time
- 11.4 Time Change
- 11.5 Extension Due to Delays
- 11.6 Essence of Contract
- 11.7 Reasonable Completion Time
- 11.8 Delay Damages

ARTICLE 12 - QUALITY ASSURANCE

- 12.1 Warranty and Guaranty
- 12.2 Access to Work
- 12.3 Tests and Inspections
- 12.4 Uncovering Work
- 12.5 CITY May Stop the Work
- 12.6 Correction of Removal of Defective Work
- 12.7 One Year Correction Period
- 12.8 Acceptance of Defective Work
- 12.9 CITY may Correct Defective Work

ARTICLE 13 - PAYMENTS TO CONTRACTOR AND COMPLETION

- 13.1 Schedule of Values
- 13.2 Preliminary Payments
- 13.3 Application for Progress Payment
- 13.4 Review of Applications for Progress Payments
- 13.5 Stored Materials and Equipment
- 13.6 CONTRACTOR's Warranty of Title
- 13.7 Withholding of Payments
- 13.8 Retainage
- 13.9 Request for Release of Funds
- 13.10 Substantial Completion
- 13.11 Access Following Substantial Completion
- 13.12 Final Inspection
- 13.13 Final Application for Payment
- 13.14 Final Payment and Final Completion
- 13.15 Final Acceptance

- 13.16 CONTRACTOR's Continuing Obligation
- 13.17 Waiver of Claims by CONTRACTOR
- 13.18 No Waiver of Legal Rights

ARTICLE 14 - SUSPENSION OF WORK, DEFAULT, AND TERMINATION

- 14.1 CITY May Suspend Work
- 14.2 Default of Contract
- 14.3 Rights or Remedies
- 14.4 Convenience Termination

ARTICLE 15 - CLAIMS AND DISPUTES

- 15.1 Notification
- 15.2 Presenting Claim
- 15.3 Claim Validity, Additional Information & Project Manager's Action
- 15.4 Contracting Officer's Decision
- 15.5 Notice of Appeal
- 15.6 City Manager's Decision

ACKNOWLEDGMENT

The City of Unalaska, "General Conditions" are based on the "Standard General Conditions of the Construction Contract" as published by the National Society of Professional Engineers (document number 1910-8, 1983 edition) on behalf of the Engineers Joint Construction Documents Committee. Portions of the NSPE General Conditions are reprinted herein by the express permission of NSPE to the State of Alaska, which supplied these General Conditions to the City of Unalaska. Modifications to the NSPE text are made to provide for State laws, regulations, and established procedures.

The granting of permission by NSPE to allow the State of Alaska to reprint portions of the NSPE document 1910-8, 1983 does not constitute approval of the State of Alaska General Conditions or the subsequently developed City of Unalaska General Conditions.

Insurance requirements were modified March, 2001. Brooks Chandler review comments were incorporated January, 2005 and March, 2008.

ARTICLE 1 - DEFINITIONS

Wherever used in the Contract Documents the following terms, or pronouns in place of them, are used, the intent and meaning, unless a different intent or meaning is clearly indicated, shall be interpreted as set forth below.

The titles and headings of the Sections, Subsections and Articles herein are intended for convenience of reference and shall not be considered as having bearing on their interpretation.

Whenever used in the Specifications or other Contract Documents the following terms have the meaning indicated which are applicable to both the singular and plural thereof. Working titles which have a masculine gender, are intended to refer to persons of either sex.

Terms not defined below shall have their ordinary accepted meanings within the context in which they are used. "Webster's Third New International Dictionary of the English Language, Unabridged, Copyright 1961", or subsequent revision thereof; shall provide ordinarily accepted meanings. Words which have a well-known technical or trade meaning when used to describe work, materials or equipment shall be interpreted in accordance with such meaning. Words defined in Article 1 are capitalized throughout these General Conditions.

Addenda - All clarifications, corrections, or changes issued graphically or in writing by the CITY after the advertisement but prior to the opening of bids.

Advertisement - The public announcement, as required by law, inviting Bids for work to be performed or materials to be furnished.

Application for Payment - The form provided by the CITY which is used by the CONTRACTOR in requesting progress or final payments and which is to include such supporting documentation as is required by the Contract Documents.

Approved or Approval - Means written approval by Contracting Officer or his authorized representative as defined in Article 2.1.

A.S. - Initials which stand for Alaska Statute.

Award - The acceptance, by the City, of the successful Bid.

Bid - The offer of a bidder, on the prescribed form to perform the work at the prices quoted.

Bid Bond - A type of bid Guarantee.

Bid Guaranty - The security furnished with a bid to guarantee that the bidder will enter into a contract if his proposal is accepted by the Department.

Bidder - Any individual, firm, corporation or any acceptable combination thereof, or joint venture submitting a bid for the advertised Work.

Calendar Day - Every day shown on the calendar, beginning and ending at midnight.

Change Order - A written order by the CITY directing changes to the contract, within its general scope.

City - The City of Unalaska, Alaska. References to "owner" or "Contracting Agency" mean the city.

Conditions of the Contract - Those portions of the Contract Documents which define the rights and responsibilities of the contracting parties and of others involved in the Work. The Conditions of the Contract include General Conditions, Supplementary Conditions and other Conditions.

Contract - The written agreement between the CITY and the CONTRACTOR setting forth the obligations of the parties and covering the Work to be performed, all as required by the Contract Documents.

Contract Documents - The Contract Form, Addenda, the Bidding Requirements and CONTRACTOR's Bid (including all appropriate bid tender forms), the Bonds, the Conditions of the Contract and all other Contract Requirements, the Specifications, and the Drawings furnished by the CITY to the CONTRACTOR, together with all change orders and documents approved by the Contracting Officer for inclusion, modifications and supplements issued on or after the Effective Date of the Contract.

Contracting Officer - The person authorized to enter into and administer the contract on behalf of the CITY. He has authority to make findings, determinations and decisions with respect to the contract and, when necessary, to modify or terminate the contract. The Contracting Officer is identified on the Construction Contract.

Contractor - The individual, firm, corporation or any acceptable combination thereof, contracting with the CITY for performance of the Work.

Contract Price - The total moneys payable by the CITY to the CONTRACTOR under the terms of the Contract Documents.

Contract Time - The number of Calendar Days or the date specified in the Construction Contract and authorized time extensions which identify how much time the CONTRACTOR is allowed to achieve Final Completion.

Consultant - A person, firm, agency or corporation retained by the CITY to prepare Contract Documents, perform construction administration services, or other Project related services.

Defective - An adjective which refers to Work that is unsatisfactory, faulty or deficient, or does not conform to the Contract Documents, or does not meet the requirements of any inspection, reference standard, test or approval referred to in the Contract Documents, or has been damaged prior to the CITY's approval of final payment.

Directive - A written communication to the CONTRACTOR from the Contracting Officer interpreting or enforcing a contract requirement or ordering commencement of an item of work.

Drawings - The drawings which show the character and scope of the Work to be performed and which have been furnished by the CITY or the CITY's Consultant and are by reference made a part of the Contract Documents.

Effective Date of the Contract - The date on which the Contract is fully executed by both CONTRACTOR and the CITY.

Final Completion - The Work (or specified part thereof) has progressed to the point that all Work is complete as determined by the Contracting Officer.

General Requirements - Sections of Division 1 of the Specifications which contain administrative and procedural requirements as well as requirements for temporary facilities which apply to Specification Divisions 2 through 16.

Holidays - The City of Unalaska recognizes the following holidays:

1. New Years Day - January 1
2. President's Day - Third Monday in February
3. Memorial Day - Last Monday in May
4. Independence Day - July 4
5. Labor Day - First Monday in September
6. Veteran's Day - November 11
7. Thanksgiving Day - Fourth Thursday in November
8. Christmas Day - December 25

If any holiday listed above falls on a Saturday, Saturday and the preceding Friday are both legal holidays. If the holiday should fall on a Sunday, Sunday and the following Monday are both legal holidays.

Install - Means to build into the Work, ready to be used in complete and operable condition and in compliance with Contract Documents.

Invitation for Bids or Invitation to Bid - A portion of the Bidding Documents soliciting bids for the Work to be performed.

Notice of Intent to Award - The written notice by the CITY to all Bidders identifying the apparent successful Bidder and establishing the CITY's intent to execute the Contract when all conditions required for execution of the Contract are met.

Notice to Proceed - A written notice to the CONTRACTOR to begin the Work and establishing the date on which the Contract Time begins.

Payment Bond - The security furnished by the CONTRACTOR and his surety to guarantee payment of the debts covered by the bond.

Performance Bond - The security furnished by the CONTRACTOR and his surety to guarantee performance and completion of the work in accordance with the contract.

Project - The total construction, of which the Work performed under the Contract Documents is the whole or a part, where such total construction may be performed by more than one prime contractor.

Project Manager - The authorized representative of the Contracting Officer who is responsible for administration of the Contract.

Proposal - The offer of a bidder, on the prescribed form to perform the work at the prices quoted.

Proposal Guaranty - The security furnished with a proposal to guarantee that the bidder will enter into a contract if his proposal is accepted by the Department.

Regulatory Requirement - Laws, rules, regulations, ordinances, codes and/or orders of the United States, State of Alaska or City of Unalaska to the extent applicable to the Work.

Shop Drawings - All drawings, diagrams, illustrations, schedules and other data which are specifically prepared by or for the CONTRACTOR to illustrate some portion of the Work and all illustrations, brochures, standard schedules, performance charts, instructions, diagrams and other information prepared by a Supplier and submitted by the CONTRACTOR to illustrate material, equipment, fabrication, or erection for some portion of the Work.

Specification - Those portions of the Contract Documents consisting of written technical descriptions of materials, equipment, construction systems, standards and workmanship as applied to the Work and certain administrative and procedural details applicable thereto.

Subcontractor - An individual, firm, or corporation to whom the CONTRACTOR sublets part of the contract.

Substantial Completion - Although not fully completed, the Work (or a specified part thereof) has progressed to the point where, in the opinion of the CITY as evidenced by the CITY's written notice, it is sufficiently complete, in accordance with the Contract Documents, so that the Work (or specified part) can be utilized for the purposes for which it is intended. The terms "Substantially Complete" and "Substantially Completed" as applied to any Work refer to Substantial Completion thereof.

Supplemental Agreement - A written agreement between the CONTRACTOR and the CITY covering work that is not within the general scope of the contract.

Surety - The corporation, partnership, or individual, other than the CONTRACTOR, executing a bond furnished by the CONTRACTOR.

Unit Price Work - Work to be paid for on the basis of unit prices.

Using Agency - The entity who will occupy or use the completed Work.

Work - Work is the act of, and the result of, performing services, furnishing labor, furnishing and incorporating materials and equipment into the Project and performing other duties and obligations, all as required by the Contract Documents. Such Work, however incremental, will culminate in the entire completed Project, or the various separately identifiable parts thereof.

ARTICLE 2 - AUTHORITIES AND LIMITATIONS

2.1 Authorities and Limitations:

- 2.1.1 The Contracting Officer alone, shall have the power to bind the CITY and to exercise the rights, responsibilities, authorities and functions vested in the Contracting Officer by the Contract Documents, except that the Contracting Officer shall have the right to designate in writing authorized representatives to act for him. Wherever any provision of the Contract Documents specifies an individual or organization, whether Governmental or private, to perform any act on behalf of or in the interests of the CITY that individual or organization shall be deemed to be the Contracting Officer's authorized representative under this Contract but only to the extent so specified. The Contracting Officer may, at any time during the performance of this Contract, vest in any such authorized representatives additional power and authority to act for the Contracting Officer or designate additional representatives, specifying the extent of their authority to act for the Contracting Officer; a copy of each document vesting additional authority in or removing that authority from an authorized representative or designating an additional authorized representative shall be furnished to the CONTRACTOR. The City Council reserves the right to appoint a new Contracting Officer without affecting any of the CONTRACTOR's obligations to the CITY under this Contract.
- 2.1.2 The CONTRACTOR shall perform the Work in accordance with any written order (including but not limited to instruction, direction, interpretation or determination) issued by an authorized representative in accordance with the authorized representative's authority to act for the Contracting Officer. The CONTRACTOR assumes all the risk and consequences of performing the Work in accordance with any order (including but not limited to instruction, direction, interpretation or determination) of anyone not authorized to issue such order, and of any order not in writing.
- 2.1.3 Should the Contracting Officer or his authorized representative designate Consultant(s) to act for the CITY as provided for in Paragraph 2.1.1, the performance or nonperformance of the Consultant under such authority to act, shall not give rise to any contractual obligation or duty of the Consultant to the CONTRACTOR, any Subcontractor, any Supplier, or any other organization performing any of the Work or any Surety representing them.
- 2.1.4 The term "Contracting Officer" when used in the text of these General Conditions or other Contract Documents following this section shall also mean any duly authorized representative of the Contracting Officer when authorized in accordance with Paragraph 2.1.1.

2.2 Evaluations by Contracting Officer:

- 2.2.1 The Contracting Officer will decide all questions which may arise as to;
- a. Quality and acceptability of materials furnished;
 - b. Quality and acceptability of Work performed;
 - c. Compliance with the Schedule of Progress;
 - d. Interpretation of Contract Documents;
 - e. Acceptable fulfillment of the Contract on the part of the CONTRACTOR.
- 2.2.2 In order to avoid cumbersome terms and confusing repetition of expressions in the Contract Documents whenever the terms "as ordered", "as directed", "as required", "as approved", or terms of like effect or import are used, or the adjectives "reasonable", "suitable", "acceptable", "proper" or "satisfactory" or adjectives of like effect or import are used it shall be understood as if the expression were followed by the words "the Contracting Officer". When such terms are used to describe a requirement, direction, review or judgment of the Contracting Officer as to the Work, it is intended that such requirement, direction, review or judgment will be solely to evaluate the Work for compliance with the Contract Documents (unless there is a specific statement indicating otherwise).

2.2.3 The use of any such term or adjective shall not be effective to assign to the CITY any duty or authority to supervise or direct the furnishing or performance of the Work or any duty or authority to undertake responsibility contrary to the provision of paragraphs 2.3 or 2.4.

2.3 Means & Methods:

The means, methods, techniques, sequences or procedures of construction, or safety precautions and the program incident thereto, and the failure to perform or furnish the Work in accordance with the Contract Documents are the sole responsibility of the CONTRACTOR.

2.4 Visits to Site:

The Contracting Officer will make visits to the site and approved remote storage sites at intervals appropriate to the various stages of construction to observe the progress and quality of the executed Work and to determine, in general, if the Work is proceeding in accordance with the Contract Documents. Such observations or the lack of such observations shall in no way relieve the CONTRACTOR from his duty to perform the Work in accordance with the Contract Documents.

ARTICLE 3 - CONTRACT DOCUMENTS: INTENT, AMENDING, REUSE

3.1 Incomplete Contract Documents:

The submission of a Bid by the Bidder is considered a representation that the Bidder examined the Contract Documents to make certain that all sheets and pages were provided and that the Bidder is satisfied as to the conditions to be encountered in performing the Work. The CITY expressly denies any responsibility or liability for a Bid submitted on the basis of an incomplete set of Contract Documents.

3.2 Copies of Contract Documents:

The CITY shall furnish to the CONTRACTOR up to ten copies of the Contract Documents. Additional copies will be furnished, upon request, at the cost of reproduction.

3.3 Scope of Work:

The Contract Documents comprise the entire Contract between the CITY and the CONTRACTOR concerning the Work. The Contract Documents are complementary; what is called for by one is as binding as if called for by all. The Contract Documents will be construed in accordance with the Regulatory Requirements.

It is specifically agreed between the parties executing this Contract that it is not intended by any of the provisions of the Contract to create in the public or any member thereof a third party benefit, or to authorize anyone not a party to this Contract to maintain a suit pursuant to the terms or provisions of the Contract.

3.4 Intent of Contract Documents:

3.4.1 It is the intent of the Contract Documents to describe a functionally complete Project to be constructed in accordance with the Contract Documents. Any Work, materials or equipment that may reasonably be inferred from the Contract Documents as being required to produce the intended result will be supplied, without any adjustment in Contract Price or Contract Time, whether or not specifically called for.

3.4.2 Reference to standard specifications, manuals or codes of any technical society, organization or association, or to the Regulatory Requirements, whether such reference be specific or by implication, shall mean the edition stated in the Contract Documents or if not stated the latest standard specification, manual, code or Regulatory Requirements in effect at the time of Advertisement for the Project (or, in the Effective Date of the Contract if there was no Advertisement). However, no provision of any referenced standard specification, manual or code (whether or not specifically incorporated by reference in the Contract Documents) shall be effective to change the duties and responsibilities of the CITY and the CONTRACTOR, or any of their consultants, agents or employees from those set forth in the Contract Documents, nor shall it be effective to assign to the CITY or any of the CITY's consultants, agents or employees, any duty or authority to supervise or direct the furnishing

or performance of the Work or any duty or authority to undertake responsibility contrary to the provisions of paragraphs 2.3 or 2.4.

3.5 Discrepancy in Contract Documents:

3.5.1 Before undertaking the Work, the CONTRACTOR shall carefully study and compare the Contract Documents and check and verify pertinent figures, and dimensions shown thereon and all applicable field measurements. Work in the area by the CONTRACTOR shall imply verification of figures, dimensions and field measurements. If, during the above study or during the performance of the Work, the CONTRACTOR finds a conflict, error, discrepancy or omission in the Contract Document, or a discrepancy between the Contract Documents and any standard specification, manual, code, or Regulatory Requirement which affects the Work, The CONTRACTOR shall promptly report such discrepancy in writing to the Contracting Officer. The CONTRACTOR shall obtain a written interpretation or clarification from the Contracting Officer before proceeding with any Work affected thereby. Any adjustment made by the CONTRACTOR without this determination shall be at his own risk and expense. However, the CONTRACTOR shall not be liable to the CITY for failure to report any conflict, error or discrepancy in the Contract Documents unless the CONTRACTOR had actual knowledge thereof or should reasonably have knowledge thereof.

3.5.2 Discrepancy - Order of Precedence:

When conflicts, errors, or discrepancies within the Contract Documents exist, the order of precedence from most governing to least governing will be as follows:

- Supplementary Conditions
- General Conditions
- General Requirements
- Technical Specifications
- Drawings (recorded dimensions will govern over scaled dimensions, large details over small scale, schedules over plans, architectural drawings over structural drawings over mechanical and electrical drawings)

3.6 Clarifications and Interpretations:

The Contracting Officer will issue with reasonable promptness such written clarifications or interpretations of the requirements of the Contract Documents as the Contracting Officer may determine necessary, which shall be consistent with or reasonably inferable from the overall intent of the Contract Documents.

3.7 Reuse of Documents:

Neither the CONTRACTOR nor any Subcontractor, or other person or organization performing or furnishing any of the Work under a direct or indirect contract with the CITY shall have or acquire any title to or ownership rights in any of the Contract Documents (or copies thereof) prepared by or for the CITY and they shall not reuse any of the Contract Documents on extensions of the Project or any other project without written consent of the Contracting Officer.

Contract Documents prepared by the CONTRACTOR in connection with the Work shall become the property of the CITY.

ARTICLE 4 - LANDS AND PHYSICAL CONDITIONS

4.1 Availability of Lands:

The CITY shall furnish as indicated in the Contract Documents, the lands upon which the Work is to be performed, rights-of-way and easements for access thereto, and such other lands which are designated for use of the CONTRACTOR in connection with the Work. Easements for permanent structures or permanent changes in existing facilities will be obtained and paid for by the CITY, unless otherwise provided in the Contract Documents. The CONTRACTOR shall provide for all additional lands and access thereto that may be required for temporary construction facilities or storage of materials and equipment.

4.2 Visit to Site:

The submission of a Bid by the CONTRACTOR is considered a representation that the CONTRACTOR has visited and carefully examined the site and is satisfied as to the conditions to be encountered in performing the Work and as to the requirements of the Contract Documents.

4.3 Explorations and Reports:

The Supplementary Conditions identify those reports of explorations and tests of subsurface conditions at the site that have been utilized by the CITY in preparation of the Contract Documents. The CONTRACTOR may rely upon the accuracy of the factual data contained in such reports, but not upon interpretations or opinions drawn from such factual data contained therein or for the completeness or sufficiency thereof. Except as indicated in the immediately preceding sentence and in paragraphs 4.4 and 9.9, CONTRACTOR shall have full responsibility with respect to surface and subsurface conditions at the site.

4.4 Utilities:

4.4.1 The horizontal and vertical locations of known underground utilities as shown or indicated by the Contract Documents are approximate and are based on information and data furnished to the CITY by the owners of such underground utilities.

4.4.2 The CONTRACTOR shall have full responsibility for:

- a. Reviewing and checking all information and data concerning utilities.
- b. Locating all underground utilities shown or indicated in the Contract Documents which are affected by the Work.
- c. Coordination of the Work with the owners of all utilities during construction.
- d. Safety and protection of all utilities as provided in paragraph 6.17.
- e. Repair of any damage to utilities resulting from the Work in accordance with 4.4.4 and 4.5.

4.4.3 If Work is to be performed by any utility owner, the CONTRACTOR shall cooperate with such owners to facilitate the Work.

4.4.4 In the event of interruption to any utility service as a result of accidental breakage or as a result of being exposed or unsupported, the CONTRACTOR shall promptly notify the utility owner and the Contracting Officer. If service is interrupted repair work shall be continuous until the service is restored. No Work shall be undertaken around fire hydrants until provisions for continued service have been approved by the local fire authority.

4.5 Damaged Utilities:

When utilities are damaged by the CONTRACTOR, the utility owner shall have the choice of repairing the utility or having the CONTRACTOR repair the utility. In the following circumstances, the CONTRACTOR shall reimburse the utility owner for repair costs or provide at no cost to the utility owner or the CITY, all materials, equipment and labor necessary to complete repair of the damage:

- a. When the utility is shown or indicated in the Contract Documents.
- b. When the utility has been located by the utility owner.
- c. When no locate was requested by the CONTRACTOR for utilities shown or indicated in the Contract Documents.
- d. All visible utilities.

- e. When the CONTRACTOR could have, otherwise, reasonably been expected to be aware of such utility.

4.6 Utilities Not Shown or indicated.

If, while directly performing the Work, an underground utility is uncovered or revealed at the site which was not shown or indicated in the Contract Documents and which the CONTRACTOR could not reasonably have been expected to be aware of, the CONTRACTOR shall, promptly after becoming aware thereof and before performing any Work affected thereby (except in an emergency as permitted by paragraph 6.19) identify the owner of such underground facility and give written notice thereof to that owner and to the Contracting Officer. The Contracting Officer will promptly review the underground utility to determine the extent to which the Contract Documents and the Work should be modified to reflect the impacts of the discovered utility. The Contract Documents will be amended or supplemented to the extent necessary through the issuance of a change document by the Contracting Officer. During such time, the CONTRACTOR shall be responsible for the safety and protection of such underground utility as provided in paragraph 6.17. The CONTRACTOR may be allowed an increase in the Contract Price or an extension of the Contract Time, or both, to the extent that they are directly attributable to the existence of any underground utility that was not shown or indicated in the Contract Documents and which the CONTRACTOR could not reasonably have been expected to be aware of.

4.7 Survey Control:

The CITY will identify sufficient horizontal and vertical control data to enable the CONTRACTOR to survey and layout the Work. All survey work shall be performed under the direct supervision of a registered Land Surveyor when required by paragraph 7.8.

ARTICLE 5 - BONDS, INSURANCE, AND INDEMNIFICATION

5.1 Delivery of Bonds:

When the CONTRACTOR delivers the executed Contract to the Contracting Officer, the CONTRACTOR shall also deliver to the Contracting Officer such bonds as the CONTRACTOR may be required to furnish in accordance with paragraph 5.2.

5.2 Bonds:

The CONTRACTOR shall furnish Performance and Payment Bonds, each in an amount as shown on the Contract as security for the faithful performance and payment of all CONTRACTOR's obligations under the Contract Documents. These bonds shall remain in effect for one year after the date of Final Completion and until all obligations under this Contract, except special guarantees as per 12.7, have been met. All bonds shall be furnished on forms provided by the CITY (or copies thereof) and shall be executed by such Sureties as are authorized to do business in the State of Alaska. The contracting Officer may at his option copy the Surety with notice of any potential default or liability.

5.3 Replacement of Bond and Surety:

If the Surety on any bond furnished in connection with this Contract is declared bankrupt or becomes insolvent or its right to do business is terminated in any state where any part of the Project is located or it ceases to meet the requirements of paragraph 5.2, or otherwise becomes unacceptable to the CITY, or if any such Surety fails to furnish reports as to his financial condition as requested by the CITY, the CONTRACTOR shall within five days thereafter substitute another bond and Surety, both of which must be acceptable to CITY.

5.4 Insurance Requirements:

- 5.4.1. The contractor shall carry and maintain throughout the life of this contract, at its own expense, insurance not less than the amounts and coverage herein specified, and the City of Unalaska, its employees and agents shall be named as additional insured under the insurance coverage so specified and where allowed, with respect to the performance of the work. There shall be no right of subrogation against the City or its agents performing work in connection with the work, and this **waiver of subrogation** shall be endorsed upon the policies. Insurance shall be placed with companies acceptable to the City of Unalaska; and these policies providing coverage thereunder shall contain provisions that no cancellation or material changes in the policy relative to this project shall become effective except upon **30 days** prior written notice thereof to the City of Unalaska.

- 5.4.2. Prior to commencement of the work, the contractor shall furnish certificates to the City of Unalaska, in duplicate, evidencing that the Insurance policy provisions required hereunder are in force. Acceptance by the City of Unalaska of deficient evidence does not constitute a waiver of contract requirements.
- 5.4.3. The contractor shall furnish the City of Unalaska with certified copies of policies upon request. The minimum coverages and limits required are as follows:
1. **Workers' Compensation** insurance in accordance with the statutory coverages required by the State of Alaska and **Employers Liability** insurance with limits not less than **\$1,000,000** and, where applicable, insurance in compliance with any other statutory obligations, whether State or Federal, pertaining to the compensation of injured employees assigned to the work, including but not limited to Voluntary Compensation, Federal Longshoremen and Harbor Workers Act, Maritime and the Outer Continental Shelf's Land Act.
 2. **Commercial General Liability** with limits not less than **\$1,000,000** per Occurrence and **\$2,000,000** Aggregate for Bodily Injury and Property Damage, including coverage for Premises and Operations Liability, Products and Completed Operations Liability, Contractual Liability, Broad Form Property Damage Liability and Personal Injury Liability. Coverage shall not contain any exclusion of Explosion, Collapse, or Underground. Coverage is to be endorsed to include a per project aggregate. Additionally, such insurance shall be considered primary to any other insurance carried by the City of Unalaska and the insurer will endorse the policy accordingly.
 3. **Commercial Automobile Liability** on all owned, non-owned, hired and rented vehicles with limits of liability of not less than **\$1,000,000** Combined Single Limit for Bodily Injury and Property Damage per each accident or loss.
 4. If applicable, Contractor's Equipment insurance covering all of the contractor's equipment and machinery to be used in connection with the performance of the work specified in this contract. This coverage requirement may be waived at the discretion of the City of Unalaska if the Contractor self-insures the equipment and will waive all right of recovery against the City of Unalaska in writing.
 5. **Umbrella/Excess Liability** insurance coverage of not less than **\$1,000,000** per occurrence and annual aggregate providing coverage in excess of General Liability, Auto Liability, and Employers Liability.
 6. If work involves use of aircraft, Aircraft Liability insurance covering all owned and non-owned aircraft with a per occurrence limit of not less than \$1,000,000.
 7. If work involves use of watercraft, Protection and Indemnity insurance with limits not less than \$1,000,000 per occurrence. Hull and Machinery coverage is to be carried on the vessel for the full current market value. This coverage requirement may be waived at the discretion of the City of Unalaska if the contractor self-insures the equipment and will waive all rights of recovery against the City of Unalaska in writing.
 8. Where applicable, **Professional Liability** insurance with limits of not less than \$1,000,000 per claim and \$1,000,000 aggregate, subject to a maximum deductible of \$10,000 per claim. The City of Unalaska has the right to negotiate increase of deductibles subject to acceptable financial information of the policyholder.
 9. Where applicable, Pollution Liability insurance with a project limit of not less than \$1,000,000 subject to a maximum deductible of \$10,000 to include coverage for Asbestos, Hazardous Materials, Lead or other related environmental hazards. The City of Unalaska has the right to negotiate increase of deductibles subject to acceptable financial information of the policyholder.

In the event Asbestos, Hazardous Materials, Lead or other related environmental hazards are transported by vehicle and/or marine vessel, the operator of such vehicles and vessels shall provide a Certificate of Insurance for the transportation of such materials (including loading and unloading) with limits of not less than \$1,000,000.

10. **Builder's Risk Insurance:** Coverage shall be provided on an "All Risk" completed value basis and protect the interests of the City, the contractor and his subcontractors. Coverage shall include all materials, equipment and supplies that are intended for specific installation in the project while such materials, supplies and equipment are located at the project site and in transit from port of arrival to job site and while temporarily located away from the project site.
- 5.4.4. Any deductibles or self-insured retentions must be declared to and approved by the City. At the option of the City, either: the insurer shall reduce or eliminate such deductibles or self-insured retentions as respects the City, its officers, officials, employees and volunteers; or the contractor shall provide a financial guarantee satisfactory to the City guaranteeing payment of losses and related investigations, claim administration and defense expense.
- 5.4.5. All insurance policies as described above are required to be written on an "occurrence" basis. In the event occurrence coverage is not available, the contractor agrees to maintain "claims made" coverage for a minimum of two years after project completion.
- 5.4.6. If the contractor employs subcontractors to perform any work hereunder, the contractor agrees to require such subcontractors to obtain, carry, maintain, and keep in force during the time in which they are engaged in performing any work hereunder, policies of insurance which comply with the requirements as set forth in this section. This requirement is applicable to subcontractors of any tier.
- 5.4.7. The contractor is required to maintain all certificates of insurance during the course of the project and for a minimum of three (3) years following the completion of such project. It is further agreed, that upon request by the City of Unalaska, the Contractor will provide copies of any and all subcontractor certificates of insurance for review of compliance.
- 5.4.8. Failure by the Contractor to maintain the required insurance coverage or to comply with the above, may, at the option of the City of Unalaska, be deemed Defective Work and remedied in accordance with the contract.
- 5.5 Indemnification:
- 5.5.1 The CONTRACTOR and his Subcontractors will name the owner as "Additional Insured" and will provide a "Waiver of Subrogation" on all required policies of insurance.
- 5.5.2 The CONTRACTOR shall indemnify, save harmless, and defend the CITY and its agents and its employees from any and all claims or actions for injuries or damages sustained by any person or property arising directly or indirectly from the CONTRACTOR's performance of this contract; however, this provision has no effect if, but only if, the sole proximate cause of the injury or damage is the negligence of the City or its agents.

ARTICLE 6 - CONTRACTOR'S RESPONSIBILITIES

6.1 Supervision of Work:

The CONTRACTOR shall supervise and direct the Work competently and efficiently, devoting such attention thereto and applying such skills and expertise as may be necessary to perform the Work in accordance with the Contract Documents. All Work under this Contract shall be performed in a skillful and workmanlike manner. The CONTRACTOR shall be solely responsible for the means, methods, techniques, sequences and procedures of construction.

6.2 Superintendence by CONTRACTOR:

The CONTRACTOR shall keep on the Work at all times during its progress a competent resident superintendent. The Contracting Officer shall be advised in writing of the superintendent's name, local address, and telephone number. This written advice is to be kept current until Final Acceptance by the CITY. The superintendent will be the CONTRACTOR's representative at the site and shall have full authority to act and sign documents on behalf of the CONTRACTOR.

All communications given to the superintendent shall be as binding as if given to the CONTRACTOR. The CONTRACTOR shall cooperate with the Contracting Officer in every way possible.

6.3 Character of Workers:

The CONTRACTOR shall provide a sufficient number of competent, suitable qualified personnel to survey and lay out the Work and perform construction as required by the Contract Documents. The CONTRACTOR shall at all times maintain good discipline and order at the site. The Contracting Officer may, in writing, require the CONTRACTOR to remove from the Work any employee the Contracting Officer deems incompetent, careless, or otherwise detrimental to the progress of the Work, but the Contracting Officer shall have no duty to exercise this right.

6.4 CONTRACTOR to Furnish:

Unless otherwise specified in the General Requirements, the CONTRACTOR shall furnish and assume full responsibility for all materials, equipment and machinery, tools, appliances, fuel, power, light, heat, telephone, water, sanitary facilities, temporary facilities and all other facilities and incidentals necessary for the furnishing, performance, testing, start-up and completion of the Work.

6.5 Materials and Equipment:

All materials and equipment shall be of specified quality and new, except as otherwise provided in the Contract Documents. If required by the Contracting Officer, the CONTRACTOR shall furnish satisfactory evidence (including reports of required tests) as to the kind and quality of materials and equipment. All materials and equipment shall be applied, installed, connected, erected, used, cleaned, and conditioned in accordance with the instructions of the applicable Supplier except as otherwise provided in the Contract Documents; but no provision of any such instructions will be effective to assign to the CITY or any of the CITY's Consultants, agents or employees, any duty or authority to supervise or direct the furnishing or performance of the Work or any duty or authority to undertake responsibility contrary to the provisions of paragraphs 2.3 or 2.4.

6.6 Anticipated Schedules:

6.6.1 Within reasonable time prior to the preconstruction conference the CONTRACTOR shall submit to the Contracting Officer for review an anticipated progress schedule indicating the starting and completion dates of the various stages of the Work.

6.6.2 Within fifteen days after the date of the Notice to Proceed, the CONTRACTOR shall submit to the Contracting Officer for review:

Anticipated schedule of Shop Drawing submissions; and Anticipated Schedule of Values for all of the Work which will include quantities and prices of items aggregating the Contract Price and will subdivide the Work into component parts in sufficient detail to serve as the basis for progress payments during construction. Such prices will include an appropriate amount of overhead and profit applicable to each item of Work which will be confirmed in writing by the CONTRACTOR at the time of submission.

6.7 Finalizing Schedules:

Prior to processing the first Application for Payment the Contracting Officer and the CONTRACTOR will finalize schedules required by paragraph 6.6.

Acceptance by the CITY of the progress schedule, will neither impose on the CITY nor relieve the CONTRACTOR from full responsibility for the progress or scheduling of the Work. If accepted, the finalized schedule of Shop Drawing and other required submissions will be acceptable to the CITY as providing a workable arrangement for processing the submissions. If accepted the finalized Schedule of Values will be acceptable to the CITY as an approximation of anticipated value of Work accomplished over the anticipated Contract Time. Receipt and acceptance of a schedule submitted by the CONTRACTOR shall not be construed to assign responsibility for performance or contingencies to the CITY or relieve the CONTRACTOR of his responsibility to adjust his forces, equipment, and work schedules as may be necessary to insure completion of the Work within prescribed Contract Time. Should the progress of the Work be discontinued for any reason, the CONTRACTOR shall notify the Contracting Officer at least 24 hours in advance of resuming operations.

6.8 Adjusting Schedules:

Upon substantial changes to the schedule or upon request, the CONTRACTOR shall submit to the Contracting Officer for acceptance (to the extent indicated in paragraph 6.7 and the General Requirements) adjustments in the schedules to reflect the actual present and anticipated progress of the Work.

6.9 Substitutes or "Or-Equal" Items:

- 6.9.1 Whenever materials or equipment are specified or described in the Contract Documents by using the name of a proprietary item or the name of a particular Supplier, the naming of the item is intended to establish the type, function and quality required. Unless the name is followed by words indicating that no substitution is permitted, materials or equipment of other Suppliers may be accepted by the Contracting Officer only if sufficient information is submitted by the CONTRACTOR which clearly demonstrates to the Contracting Officer that the material or equipment proposed is equivalent or equal in all aspects to that named. The procedure for review by the Contracting Officer will include the following as supplemented in the General Requirements.
- 6.9.2 Requests for review of substitute items of material and equipment will not be accepted by the Contracting Officer from anyone other than the CONTRACTOR.
- 6.9.3 If the CONTRACTOR wishes to furnish or use a substitute item of material or equipment, the CONTRACTOR shall make written application to the Contracting Officer for acceptance thereof, certifying that the proposed substitute will perform adequately the functions and achieve the results called for by the general design, be similar and of equal substance to that specified and be suited to the same use as that specified. The application will state that the evaluation and acceptance of the proposed substitute will not delay the CONTRACTOR's achievement of Substantial Completion on time, whether or not acceptance of the substitute for use in the Work will require a change in any of the Contract Documents (or in the provisions of any other direct contract with the CITY for work on the Project) to adapt the design to the proposed substitute and whether or not incorporation or use of the substitute in connection with the Work is subject to payment of any license fee or royalty.
- 6.9.4 All variations of the proposed substitute from that specified will be identified in the application and available maintenance, repair and replacement service will be indicated. The application will also contain an itemized estimate of all costs that will result directly or indirectly from acceptance of such substitute, including costs of redesign and claims of other contractors affected by the resulting change, all of which shall be considered by the Contracting Officer in evaluating the proposed substitute. The Contracting Officer may require the CONTRACTOR to furnish at the CONTRACTOR's expense additional data about the proposed substitute. The Contracting Officer may reject any substitution request which the Contracting Officer determines is not in the best interest of the CITY.

6.10 Substitute Means and Methods:

If a specific means, method, technique, sequence or procedure of construction is indicated in or required by the Contract Documents, the CONTRACTOR may furnish or utilize a substitute means, method, sequence, technique or procedure of construction acceptable to the Contracting Officer, if the CONTRACTOR submits sufficient information to allow the Contracting Officer to determine that the substitute proposed is equivalent to that indicated or required by the Contract Documents. The procedure for review by the Contracting Officer will be similar to that provided in paragraph 6.9 as applied by the Contracting Officer and as may be supplemented in the General Requirements.

6.11 Evaluation of Substitution:

The Contracting Officer will be allowed a reasonable time within which to evaluate each proposed substitute. The Contracting Officer will be the sole judge of acceptability, and no substitute will be ordered, installed or utilized without the Contracting Officer's prior written acceptance which will be evidenced by either a Change Order or a Shop Drawing approved in accordance with Sections 6.20 and 6.21. The Contracting Officer may require the CONTRACTOR to furnish at the CONTRACTOR's expense a special performance guarantee or other surety with respect to any substitute.

6.12 Dividing the Work:

The divisions and sections of the Specifications and the identifications of any Drawings shall not control the CONTRACTOR in dividing the Work among Subcontractors or Suppliers or delineating the Work to be performed by any specific trade.

6.13 Subcontractors:

The CONTRACTOR may utilize the services of licensed specialty Subcontractors on those parts of the Work which, under normal contracting practices, are performed by licensed specialty Subcontractors, in accordance with the following conditions:

- 6.13.1 The CONTRACTOR shall not award any Work to any Subcontractor without prior written approval of the Contracting Officer. This approval will not be given until the CONTRACTOR submits to the Contracting Officer a written statement concerning the proposed award to the Subcontractor which shall contain required E.E.O. documents, evidence of insurance, and a copy of the proposed subcontract executed by the subcontractor. No acceptance by the Contracting Officer of any such Subcontractor shall constitute a waiver of any right of the CITY to reject Defective Work.
- 6.13.2 The CONTRACTOR shall be fully responsible to the CITY for all acts and omissions of the Subcontractors, Suppliers and other persons and organizations performing or furnishing any of the Work under a direct or indirect contract with CONTRACTOR just as CONTRACTOR is responsible for CONTRACTOR's own acts and omissions.
- 6.13.3 All Work performed for CONTRACTOR by a Subcontractor will be pursuant to an appropriate written agreement between CONTRACTOR and the Subcontractor which specifically binds the Subcontractor to the applicable terms and conditions of the Contract Documents for the benefit of the CITY and contains waiver provisions as required by paragraph 13.17 and termination provisions as required by Article 14.
- 6.13.4 Nothing in the Contract Documents shall create any contractual relationship between the CITY and any such Subcontractor, Supplier or other person or organization, nor shall it create any obligation on the part of the CITY to pay or to see to the payment of any moneys due any such Subcontractor, Supplier or other person or organization except as may otherwise be required by Regulatory Requirements. The CITY will not undertake to settle any differences between or among the CONTRACTOR, Subcontractors, or Suppliers.
- 6.13.5 The CONTRACTOR and Subcontractors shall coordinate their work and facilitate general progress of Work. Each trade shall afford other trades every reasonable opportunity for installation of their work and storage of materials. If cooperative work of one trade must be altered due to lack of proper supervision, or failure to make proper provisions in time by another trade, such conditions shall be remedied by the CONTRACTOR with no change in Contract Price or Contract Time.
- 6.13.6 The CONTRACTOR shall include on his own payrolls any person or persons working on the contract who are not covered by written subcontract, and shall ensure that all Subcontractors include on their payrolls all persons performing work under the direction of the Subcontractor.

6.14 Use of Premises:

The CONTRACTOR shall confine construction equipment, the storage of materials and equipment and the operations of workers to the Project limits and approved remote storage sites and lands and areas identified in and permitted by Regulatory Requirements, rights-of-way, permits and easements, and shall not unreasonably encumber the premises with construction equipment or other materials or equipment. The CONTRACTOR shall assume full responsibility for any damage to any such land or area, or to the owner or occupant thereof or of any land or areas contiguous thereto, resulting from the performance of the Work. Should any claim be made against the CITY by any such owner or occupant because of the performance of the Work, the CONTRACTOR shall hold the CITY and its agencies harmless.

6.15 Structural Loading:

The CONTRACTOR shall not load nor permit any part of any structure to be loaded in any manner that will endanger the structure, nor shall the CONTRACTOR subject any part of the Work or adjacent property to stresses or pressures that will endanger it.

6.16 Record Documents:

The CONTRACTOR shall maintain in a safe place at the site one record copy of all Drawings, Specifications, Addenda, Field Memos, Work Orders, Change Orders, Supplemental Agreements, and written interpretations and clarifications (issued pursuant to paragraph 3.6) in good order and annotated to show all changes made during construction. These record documents together with all approved samples and a counterpart of all approved Shop Drawings will be available to the Contracting Officer for reference and copying. Upon completion of the Work, the annotated record documents, samples and Shop Drawings will be delivered to the Contracting Officer. Record documents shall accurately record variations in the Work which vary from requirements shown or indicated in the Contract Documents.

6.17 Safety and Protection:

The CONTRACTOR alone shall be responsible for initiating, maintaining and supervising all safety precautions and programs in connection with the Work. The CONTRACTOR shall take all necessary precautions for the safety of, and shall provide the necessary protection to prevent damage, injury or loss to:

- 6.17.1 All employees on the Work and other persons and organizations who may be affected thereby;
- 6.17.2 All the Work and materials and equipment to be incorporated therein, whether in storage on or off the site; and
- 6.17.3 Other property at the site or adjacent thereto, including trees, shrubs, lawns, walks, pavements, roadways, structures, and utilities not designated for removal, relocation or replacement in the course of construction.
- 6.17.4 The CONTRACTOR shall comply with all applicable Regulatory Requirements enacted for the safety of persons or property or to protect them from damage, injury or loss; and shall erect and maintain all necessary safeguards for such safety and protection. The CONTRACTOR shall notify owners of adjacent property and utility owners when prosecution of the Work may affect them, and shall cooperate with them in the protection, removal, relocation and replacement of their property. All damage, injury or loss to any property caused, directly or indirectly, in whole or in part, by the Contractor, any Subcontractor, Supplier or any other person or organization directly or indirectly employed by any of them to perform or furnish any of the Work or anyone for whose acts any of them may be liable, shall be remedied by the CONTRACTOR with no change in Contract Price or Contract Time except as stated in 4.6, except damage or loss attributable to unforeseeable causes beyond the control of and without the fault or negligence of the CONTRACTOR, including but not restricted to acts of God or the public enemy. The CONTRACTOR's duties and responsibilities for the safety and protection of the Work shall continue until Final Acceptance (except as otherwise expressly provided in connection with Substantial Completion).

6.18 Safety Representative:

The CONTRACTOR shall designate a responsible safety representative at the site. This person shall be the CONTRACTOR's superintendent unless otherwise designated in writing by the CONTRACTOR to the Contracting Officer.

6.19 Emergencies:

In emergencies affecting the safety or protection of persons or the Work or property at the site or adjacent thereto, the CONTRACTOR, without special instruction or authorization from the CITY, is obligated to act to prevent threatened damage, injury or loss. The CONTRACTOR shall give the Contracting Officer prompt written notice if the CONTRACTOR believes that any significant changes in the Work or variations from the Contract Documents is required because of the action taken in response to an emergency, a change will be authorized by one of the methods indicated in Paragraph 9.2, as determined appropriate by the Contracting Officer.

6.20 Shop Drawings and Samples:

- 6.20.1 After checking and verifying all field measurements and after complying with applicable procedures specified in the General Requirements, the CONTRACTOR shall submit to the Contracting Officer for review and approval in accordance with the accepted schedule of Shop Drawing submissions the required number of all

Shop Drawings, which will bear a stamp or specific written indication that the CONTRACTOR has satisfied CONTRACTOR's responsibilities under the Contract Documents with respect to the review of the submission. All submissions will be identified as the Contracting Officer may require. The data shown on the Shop Drawings will be complete with respect to quantities, dimensions, specified performance and design criteria, materials and similar data to enable the Contracting Officer to review the information as required.

- 6.20.2 The CONTRACTOR shall also submit to the Contracting Officer for review and approval with such promptness as to cause no delay in Work, all samples required by the Contract Documents. All samples will have been checked by and accompanied by a specific written indication that the CONTRACTOR has satisfied CONTRACTOR's responsibilities under the Contract Documents with respect to the review of the submission and will be identified clearly as to material, Supplier, pertinent data such as catalog numbers and the use for which intended.
- 6.20.3 Before submission of each Shop Drawing or sample the CONTRACTOR shall have determined and verified all quantities, dimensions, specified performance criteria, installation requirements, materials, catalog numbers and similar data with respect thereto and reviewed or coordinated each Shop Drawing or sample with other Shop Drawings and samples and with the requirements of the Work and the Contract Documents.
- 6.20.4 At the time of each submission the CONTRACTOR shall give the Contracting Officer specific written notice of each variation that the Shop Drawings or samples may have from the requirements of the Contract Documents, and, in addition, shall cause a specific notation to be made on each Shop Drawing submitted to the Contracting Officer for review and approval of each such variation. All variations of the proposed shop drawing from that specified will be identified in the submission and available maintenance, repair and replacement service will be indicated. The submittal will also contain an itemized estimate of all costs that will result directly or indirectly from acceptance of such variation, including costs of redesign and claims of other contractors affected by the resulting change, all of which shall be considered by the CITY in evaluating the proposed variation. If the variation may result in a change of Contract Time or Price, or contract responsibility, and is not minor in nature; the CONTRACTOR must submit a written request for Change Order with the variation to notify the CITY of his intent. The CITY may require the CONTRACTOR to furnish at the CONTRACTOR's expense additional data about the proposed variation. The Contracting Officer may reject any variation request which the Contracting Officer determines is not in the best interest of the CITY.
- 6.21 Shop Drawing and Sample Review:
- 6.21.1 The Contracting Officer will review with reasonable promptness Shop Drawings and samples, but the Contracting Officer's review will be only for conformance with the design concept of the Project and for compliance with the information given in the Contract Documents and shall not extend to means, methods, techniques, sequences or procedures of construction (except where a specific means, method, technique, sequence or procedure of construction is indicated in or required by the Contract Documents) or to safety precautions or programs incident thereto. The review of a separate item as such will not indicate acceptance of the assembly in which the item functions. The CONTRACTOR shall make corrections required by the Contracting Officer and shall return the required number of corrected copies of Shop Drawings and submit as required new samples for review. The CONTRACTOR shall direct specific attention in writing to revisions other than the corrections called for by the Contracting Officer on previous submittals.
- 6.21.2 The Contracting Officer's review of Shop Drawings or samples shall not relieve CONTRACTOR from responsibility for any variation from the requirements of the Contract Documents unless the CONTRACTOR has in writing advised the Contracting Officer of each such variation at the time of submission as required by paragraph 6.20.4. The Contracting Officer if he so determines, may give written approval of each such variation by Change Order, except that, if the variation is minor and no Change Order has been requested a specific written notation thereof incorporated in or accompanying the Shop Drawing or sample review comments shall suffice as a modification. No approval by the Contracting Officer will relieve the CONTRACTOR from responsibility for errors or omissions in the Shop Drawings or from responsibility for having complied with the provisions of paragraph 6.20.3.
- 6.21.3 Where a Shop Drawing or sample is required by the Specifications, any related Work performed prior to the Contracting Officer's review of the pertinent submission will be the sole expense and responsibility of the CONTRACTOR.

6.22 Maintenance During Construction:

The CONTRACTOR shall maintain the Work during construction and until Substantial Completion, at which time the responsibility for maintenance shall be established in accordance with paragraph 13.10.

6.23 Continuing the Work:

The CONTRACTOR shall carry on the Work and adhere to the progress schedule during all disputes or disagreements with the CITY. No work shall be delayed or postponed pending resolution of any disputes, disagreements, or claims except as the CONTRACTOR and the Contracting Officer may otherwise agree in writing.

6.24 Consent to Assignment:

The CONTRACTOR shall obtain the prior written consent of the Contracting Officer to any proposed assignment of any interest in, or part of this Contract. The consent to any assignment or transfer shall not operate to relieve the CONTRACTOR or his Sureties of any of his or its obligations under this Contract or the Performance Bonds. Nothing herein contained shall be construed to hinder, prevent, or affect an assignment of monies due, or to become due hereunder, made for the benefit of the CONTRACTOR's creditors pursuant to law.

6.25 Use of Explosives:

6.25.1 When the use of explosives is necessary for the prosecution of the Work, the CONTRACTOR shall exercise the utmost care not to endanger life or property, including new Work and shall follow all Regulatory Requirements applicable to the use of explosives. The CONTRACTOR shall be responsible for all damage resulting from the use of explosives.

6.25.2 All explosives shall be stored in a secure manner in compliance with all Regulatory Requirements, and all such storage places shall be clearly marked. Where no Regulatory Requirements apply, safe storage shall be provided not closer than 1,000 feet from any building, camping area, or place of human occupancy.

6.25.3 The CONTRACTOR shall notify each public utility owner having structures in proximity to the site of his intention to use explosives. Such notice shall be given sufficiently in advance to enable utility owners to take such steps as they may deem necessary to protect their property from injury. However, the CONTRACTOR shall be responsible for all damage resulting from the use of the explosives, whether or not, utility owners act to protect their property.

6.26 CONTRACTOR's Records:

6.26.1 Records of CONTRACTOR and Subcontractors relating to personnel, payrolls, invoices of materials, and any and all other data relevant to the performance of the Contract, must be kept on a generally recognized accounting system. Such records must be available during normal work hours to the Contracting Officer for purposes of investigation to ascertain compliance with Regulatory Requirements and provision of the Contract Documents.

6.26.2 Payroll records must contain the name and address of each employee, his correct classification, rate of pay, daily and weekly number of hours of work, deductions made, and actual wages paid. The CONTRACTOR and Subcontractors shall make employment records available for inspection by the Contracting Officer and representatives of the State of Alaska Department of Labor and Workforce Development and will permit such representatives to interview employees during working hours on the Project.

6.26.3 Records of all communications between the CITY and the CONTRACTOR and other parties, where such communications affected performance of this Contract, must be kept by the CONTRACTOR and maintained for a period of three years from Final Acceptance. The CITY or its assigned representative may perform an audit of these records during normal work hours after written notice to the CONTRACTOR.

ARTICLE 7 - LAWS AND REGULATIONS

7.1 Laws to be Observed:

GENERAL CONDITIONS

The CONTRACTOR shall keep fully informed of all Regulatory Requirements and all orders and decrees of bodies or tribunals having any jurisdiction or authority, which in any manner affect those engaged or employed on the Work, or which in any way affect the conduct of the Work. The CONTRACTOR shall at all times observe and comply with all such Regulatory Requirements, orders and decrees; and shall protect and indemnify the CITY and its representatives against claim or liability arising from or based on the violation of any such Regulatory Requirement, order, or decree whether by the CONTRACTOR, Subcontractor, or any employee of either. Except where otherwise expressly required by applicable Regulatory Requirements, the CITY shall not be responsible for monitoring CONTRACTOR's compliance with any Regulatory Requirements.

7.2 Permits, Licenses, and Taxes:

7.2.1 The CONTRACTOR shall procure all permits and licenses, pay all charges, fees and taxes, and give all notices necessary and incidental to the due and lawful prosecution of the Work. As a condition of performance of this Contract, the CONTRACTOR shall pay all Federal, State and local taxes incurred by the CONTRACTOR, in the performance of the Contract. Proof of payment of these taxes is a condition precedent to final payment by the CITY under this Contract.

7.2.2 The CONTRACTOR's certification that taxes have been paid (as contained in the Release of Contract) may be verified with the Department of Revenue and Department of Labor and Workforce Development and Unalaska City Clerk, prior to final payment.

7.2.3 If any Federal, State or local tax is imposed, charged, or repealed after the date of Bid opening and is made applicable to and paid by the CONTRACTOR on the articles or supplies herein contracted for, then the Contract shall be increased or decreased accordingly by a Change Order.

7.2.4 The Contractor shall require all Subcontractors to obtain a City of Unalaska Business License.

7.3 Patented Devices, Materials and Processes:

If the CONTRACTOR employs any design, device, material, or process covered by letters of patent, trademark or copyright, the CONTRACTOR shall provide for such use by suitable legal agreement with the patentee or owner. The CONTRACTOR and the Surety shall indemnify and save harmless the CITY and its agents, any affected third party, from any and all claims for infringement by reason of the use of any such patented design, device, material or process, or any trademark or copyright, and shall indemnify the CITY for any costs, expenses, and damages which it may be obliged to pay by reason of any infringement, at any time during the prosecution or after the completion of the Work.

7.4 Compliance of Specifications and Drawings:

If the CONTRACTOR observes that the Specifications and Drawings supplied by the CITY are at variance with any Regulatory Requirements, CONTRACTOR shall give the Contracting Officer prompt written notice thereof, and any necessary changes will be authorized by one of the methods indicated in paragraph 9.2. as determined appropriate by the Contracting Officer. If the CONTRACTOR performs any Work knowing or having reason to know that it is contrary to such Regulatory Requirements, and without such notice to the Contracting Officer, the CONTRACTOR shall bear all costs arising therefrom; however, it shall not be the CONTRACTOR's primary responsibility to make certain that the Specifications and Drawings supplied by the CITY are in accordance with such Regulatory Requirements.

7.5 Accident Prevention:

The CONTRACTOR shall comply with AS 18.60.075 and all pertinent provisions of the Construction Code Occupational Safety and Health Standards issued by the Alaska Department of Labor.

7.6 Sanitary Provisions:

The CONTRACTOR shall provide and maintain in a neat and sanitary condition such accommodations for the use of his employees and CITY representatives as may be necessary to comply with the Regulatory requirements.

7.7 Business Registration:

The Contractor shall comply with AS 08.18.011 which states, as follows: "it is unlawful for a person to submit a bid or work as a contractor until he has been issued a certificate of registration by the Department of Commerce. A partnership or joint venture shall be considered registered if one of the general partners or ventures whose name appears in the name under which the partnership or venture does business is registered." The Contractor shall obtain a City of Unalaska Business License prior to commencement of the Work to the extent required by the City of Unalaska Code of Ordinances section 9.30.101.

7.8 Professional Registration and Certification:

All craft trades, architects, engineers and land surveyors, electrical administrators, explosive handlers, and welders employed under the Contract shall specifically comply with applicable provisions of AS 08.18, 08.48, 08.40, 08.52, and 08.99. Provide copies of individual licenses within seven days following a request from the Contracting Officer.

7.9 Local Building Codes:

The CONTRACTOR shall comply with AS 35.10.025 which requires construction in accordance with applicable local building codes including the obtaining of required permits. City of Unalaska permits required for the work are identified in the Supplemental Conditions.

7.10 Air Quality Control:

The CONTRACTOR shall comply with all applicable provision of AS 46.03.04 as pertains to Air Pollution Control.

7.11 Archaeological or Paleontological Discoveries:

When the CONTRACTOR's operation encounters prehistoric artifacts, burials, remains of dwelling sites, or paleontological remains, such as shell heaps, land or sea mammal bones or tusks, the CONTRACTOR shall cease operations immediately and notify the Contracting Officer. No artifacts or specimens shall be further disturbed or removed from the ground and no further operations shall be performed at the site until so directed. Should the Contracting Officer order suspension of the CONTRACTOR's operations in order to protect an archaeological or historical finding, or order the CONTRACTOR to perform extra work, such shall be covered by an appropriate Contract change document.

7.12 Not used.

7.13 Preferential Employment:

To the fullest extent allowed by law, the CONTRACTOR shall comply with AS 36.10, as amended, which provides for preferential employment of Alaska residents.

7.14 Wages and Hours of Labor:

7.14.1 One certified copy of all payrolls shall be submitted weekly to the State Department of Labor to assure compliance with AS 36.05.040, Filing Schedule of Employees Wages Paid and Other Information. The prime CONTRACTOR shall be responsible for the submission of certified copies of payrolls of all Subcontractors. The certification shall affirm that the payrolls are current and complete, that the wage rates contained therein are not less than the applicable rates referenced in these Contract Documents, and that the classification set forth for each laborer or mechanic conforms with the work he performed. The CONTRACTOR and his Subcontractors shall attend all hearings and conferences and produce such books, papers, and documents all as requested by the Department of Labor. Should Federal funds be involved, the Contracting Agency shall also receive a copy of the CONTRACTOR's certified payrolls.

7.14.2 The following Labor provisions shall also apply to this Contract:

- a. The CONTRACTOR and his Subcontractors shall pay all employees unconditionally and not less than once a week;
- b. Wages may not be less than those stated in the advertised specifications, regardless of the contractual relationship between the CONTRACTOR or Subcontractors and laborers, mechanics, or field surveyors;

- c. The scale of wages to be paid shall be posted by the CONTRACTOR in a prominent and easily accessible place at the site of the work;
- d. The CITY shall withhold so much of the accrued payments as is necessary to pay laborers, mechanics, or field surveyors employed by the CONTRACTOR or Subcontractors the difference between
 - 1. the rates of wages required by the contract to be paid laborers, mechanics, or field surveyors on the work, and
 - 2. the rates of wages in fact received by laborers, mechanics or field surveyors.

7.15 Overtime Work Hours and Compensation:

Pursuant to 40 U.S.C. 327-330 and AS 23.10.060, the CONTRACTOR shall not require nor permit any laborer or mechanic in any workweek in which he is employed on any work under this Contract to work in excess of eight hours in any Calendar Day or in excess of forty hours in such workweek on work subject to the provisions of the Contract Work Hours and Safety Standards Act unless such laborer or mechanic receives compensation at a rate not less than one and one half times his basic rate of pay for all such hours worked in excess of eight hours in any Calendar Day or in excess of forty hours in such workweek whichever is the greater number of overtime hours. In the event of any violation of this provision, the CONTRACTOR shall be liable to any affected employee for any amounts due and penalties and to the CITY for liquidated damages. Such liquidated damages shall be computed with respect to each individual laborer or mechanic employed in violation of this provision in the sum of \$10.00 for each Calendar Day on which such employee was required or permitted to be employed on such work in excess of eight hours or in excess of the standard workweek of forty hours without payment of the overtime wages required by this paragraph.

7.16 Covenant Against Contingent Fees:

The CONTRACTOR warrants that no person or selling agent has been employed or retained to solicit or secure this Contract upon an agreement or understanding for a commission, percentage, brokerage, or contingent fee. For breach or violation of this warranty, the CITY shall have the right to annul this Contract without liability or, in its discretion, to deduct price of consideration from the Contract or otherwise recover the full amount of such commission, percentage, brokerage, or contingent fee.

7.17 Officials Not to Benefit:

No member of or delegate to the U.S. Congress, the State Legislature, Unalaska City Council or other State or City Officials shall be admitted to any share or part of this Contract, nor to any benefit that may arise there from. However, this provision shall not be construed to extend to this Contract if made with a corporation for its general benefits.

7.18 Personal Liability of Public Officials:

In carrying out any of the provisions thereof, or in exercising any power or authority granted to the Contracting Officer by the Contract, there will be no liability upon the City nor upon its agents or authorized as its representatives, either personally or as officials of the City of Unalaska, it being always understood that in such matters they act as agents and representatives of the CITY.

ARTICLE 8 - OTHER WORK

8.1 Related Work at Site:

- 8.1.1 The CITY reserves the right at any time to contract for and perform other or additional work on or near the Work covered by the Contract.
- 8.1.2 When separate contracts are let within the limits of the Project, the CONTRACTOR shall conduct his Work so as not to interfere with or hinder the work being performed by other contractors. The CONTRACTOR shall join his work with that of the others in an acceptable manner and shall perform it in proper sequence to that of others.

8.1.3 If the fact that other such work to be performed is identified or shown in the Contract Documents, the CONTRACTOR shall assume all liability, financial or otherwise, in connection with this Contract and indemnify and save harmless the City of Unalaska and its agents from any and all damages or claims that may arise because of inconvenience, delay, or loss experienced by the CONTRACTOR because of the presence and operations of other contractors.

8.1.4 If the fact that such other work to be performed was not identified or shown in the Contract Documents, written notice thereof will be given to the CONTRACTOR prior to starting any such other work. If the CONTRACTOR believes that such performance will require an increase in Contract Price or Contract Time, the CONTRACTOR shall notify the Contracting Officer of such required increase within fifteen (15) calendar days following receipt of the Contracting Officer's notice. Should the Contracting Officer find such increase(s) to be justified, a Change Order will be executed.

8.2 Access, Cutting, and Patching:

The CONTRACTOR shall afford each utility owner and any other contractor who is a party to such a direct contract with the CITY (or the CITY, if the CITY is performing the additional work with the CITY's employees) proper and safe access to the site and a reasonable opportunity for the introduction and storage of materials and equipment and the execution of such work and shall properly connect and coordinate the Work with the work of others. The CONTRACTOR shall do all cutting, fitting and patching of the Work that may be required to make its several parts come together properly and integrate with such other work, the CONTRACTOR shall not endanger any work of others by cutting, excavating or otherwise altering their work and will only cut or alter such other work with the written consent of the Contracting Officer. The duties and responsibilities of the CONTRACTOR under this paragraph are for the benefit of other contractors to the extent that there are comparable provisions for the benefit of the CONTRACTOR in said direct contracts between the CITY and other contractors.

8.3 Defective Work by Others:

If any part of the CONTRACTOR's Work depends for proper execution or results upon the work of any such other contractor, utility owner, or the CITY, the CONTRACTOR shall inspect and promptly report to the Contracting Officer in writing any delays, defects or deficiencies in such work that render it unavailable or unsuitable for such proper execution and results. The CONTRACTOR's failure to so report will constitute an acceptance of the other work as fit and proper for integration with CONTRACTOR's Work except for latent or non apparent defects and deficiencies in the other work.

8.4 Coordination:

If the CITY contracts with others for the performance of other work at the site, Contracting Officer will have authority and responsibility for coordination of the activities among the various prime contractors.

ARTICLE 9 - CHANGES

9.1 CITY's Right to Change:

Without invalidating the Contract and without notice to any Surety, the CITY may, at any time or from time to time, order additions, deletions or revisions in the Work within the general scope of the Contract, including but not limited to changes:

9.1.1 In the Contract Documents;

9.1.2 In the method or manner of performance of the Work;

9.1.3 In City-furnished facilities, equipment, materials, services, or site;

9.1.4 Directing acceleration in the performance of the Work.

9.2 Authorization of Changes within the General Scope:

Additions, deletions, or revisions in the Work within the general scope of the Contract as specified in 9.1 shall be authorized by one or more of the following ways:

- 9.2.1 Directive (pursuant to paragraph 9.3)
 - 9.2.2 A Change Order (pursuant to paragraph 9.5)
 - 9.2.3 CITY's acceptance of Shop Drawing variations from the Contract Documents as specifically identified by the CONTRACTOR as required by paragraph 6.20.4.
- 9.3 Directives:
- 9.3.1 The Contracting Officer shall provide written clarification or interpretation of the contract documents (pursuant to paragraph 3.6).
 - 9.3.2 The Contracting Officer may authorize minor variations in the Work from the requirements of the Contract Documents which do not involve an adjustment in the Contract Price or the Contract Time and are consistent with the overall intent of the Contract Documents.
 - 9.3.3 The Contracting Officer may order the Contractor to correct Defective Work or methods which are not in conformance with the Contract Documents.
 - 9.3.4 The Contracting Officer may direct the commencement or suspension of Work or emergency related work (as provided in paragraph 6.19).
 - 9.3.5 Upon the issuance of a Directive to the CONTRACTOR by the Contracting Officer, the CONTRACTOR shall immediately proceed with the performance of the work as prescribed by such Directive.
 - 9.3.6 If the CONTRACTOR believes that the changes noted in a Directive may cause an increase in the Contract Price or an extension of Contract Time, the CONTRACTOR shall immediately provide written notice to the Contracting Officer depicting such increases before proceeding with the Directive, except in the case of an emergency. If the Contracting Officer finds the increase in Contract Price or the extension of Contract Time justified, a Change Order will be issued. If however, the Contracting Officer does not find that a Change Order is justified, the Contracting Officer may direct the CONTRACTOR to proceed with the work. The CONTRACTOR shall cooperate with the Contracting Officer in keeping complete daily records of the cost of such work. If a Change Order is ultimately determined to be justified, in the absence of agreed prices and unit prices, payment for such work will be made on a cost of the work basis as provided in 10.4.
- 9.4 Change Order:

A change in Contract Time, Contract Price, or responsibility may be made for changes within the scope of the Work only by Change Order. Upon receipt of an executed Change Order, the CONTRACTOR shall promptly proceed with the work involved which will be performed under the applicable conditions of the Contract Documents except as otherwise specifically provided. Changes in Contract Price and Contract Time shall be made in accordance with Article 10 and 11.

9.5 Shop Drawing Variations:

Variations by shop drawings shall only be eligible for consideration under 9.4 when the conditions affecting the price, time, or responsibility are identified by the CONTRACTOR in writing and a request for a Change Order is submitted as per 6.20.4.

9.6 Changes Outside the General Scope; Supplemental Agreement:

Any change which is outside the general scope of the Contract, as determined by the Contracting Officer, must be authorized by the appropriate representatives of the CITY and the CONTRACTOR.

9.7 Unauthorized Work:

The CONTRACTOR shall not be entitled to an increase in the Contract Price or an extension of the Contract Time with respect to any work performed that is not required by the Contract Documents as amended, modified and supplemented as provided in this Article 9, except in the case of an emergency as provided in paragraph 6.19 and except in the case of uncovering Work as provided in paragraph 12.4.2.

9.8 Notification of Surety:

If notice of any change affecting the general scope of the Work or the provisions of the Contract Documents including, but not limited to, Contract Price or Contract Time is required by the provisions of any Bond to be given to a Surety, the giving of any such notice will be the CONTRACTOR's responsibility, and the amount of each applicable Bond will be adjusted accordingly.

9.9 Differing Site Conditions:

9.9.1 The CONTRACTOR shall promptly, and before such conditions are disturbed (except in an emergency as permitted by paragraph 6.19), notify the Contracting Officer in writing of: (1) subsurface or latent physical conditions at the site differing materially from those indicated in the Contract, and which could not have been discovered by a careful examination of the site, or (2) unknown physical conditions at the site, or an unusual nature, differing materially from those ordinarily encountered and generally recognized as inherent in work of the character provided for in this Contract. The Contracting Officer shall promptly investigate the conditions, and if the Contracting Officer finds that such conditions do materially so differ and cause an increase or decrease in the CONTRACTOR's cost of, or time required for, performance of this Contract, an equitable adjustment shall be made and the Contract modified in writing accordingly.

9.9.2 Any claim for additional compensation by the CONTRACTOR under this clause shall be made in accordance with Article 15 and shall not be allowed unless the CONTRACTOR has first given the notice required by this Contract. In the event that the Contracting Officer and the CONTRACTOR are unable to reach an agreement concerning an alleged differing site condition, the CONTRACTOR will be required to keep an accurate and detailed record which will indicate the actual cost of the work done under the alleged differing site condition. Failure to keep such a record shall be a bar to any recovery by reason of such alleged differing site conditions. The Contracting Officer shall be given the opportunity to supervise and check the keeping of such records.

ARTICLE 10 - CONTRACT PRICE; COMPUTATION AND CHANGE

10.1 Contract Price:

The Contract Price constitutes the total compensation (subject to authorized adjustments) payable to the CONTRACTOR for performing the Work. All duties, responsibilities and obligations assigned to or undertaken by the CONTRACTOR shall be at his expense without change in the Contract Price. The Contract Price may only be changed by a Change Order or Supplemental Agreement.

10.2 Claim for Price Change:

Any claim for an increase or decrease in the Contract Price shall be submitted in accordance with the terms of Article 15, and shall not be allowed unless notice requirements of this Contract have been met.

10.3 Change Order Price Determination:

The value of any work covered by a Change Order for an increase or decrease in the Contract Price shall be determined in one of the following ways:

10.3.1 Where the work involved is covered by unit prices contained in the Contract Documents, by application of unit prices to the quantities of the items involved (subject to the provisions of paragraphs 10.9.1

10.3.2 By mutual acceptance of a lump sum price which includes overhead and profit.

10.3.3 When 10.3.1 and 10.3.2 are inapplicable, on the basis of the Cost of the Work (determined as provided in paragraphs 10.4 and 10.5) plus a CONTRACTOR's fee for overhead and profit (determined as provided in paragraph 10.6).

10.4 Cost of the Work:

The term Cost of the Work means the sum of all costs necessarily incurred and paid by the CONTRACTOR in the proper performance of the work. Except as otherwise may be agreed to in writing by the CITY, such costs shall be in amount no higher than those prevailing in the locality of the Project, shall include only the following items and shall not include any of the costs itemized in paragraph 10.5:

- 10.4.1 Payroll costs for employees in the direct employ of the CONTRACTOR in the performance of the work under schedules of job classifications agreed upon by the CITY and the CONTRACTOR. Payroll costs for employees not employed full time on the work shall be apportioned on the basis of their time spent on the work. Payroll costs shall include, but not be limited to, salaries and wages plus the cost of fringe benefits which shall include social security contributions, unemployment, excise and payroll taxes, workers' or workmen's compensation, health and retirement benefits, bonuses, sick leave, vacation and holiday pay applicable thereto. Such employees shall include superintendents and foremen at the site. The expenses of performing work after regular working hours, on Saturday, Sunday or legal holidays, shall be included in the above to the extent authorized by the CITY.
- 10.4.2 Cost of all materials and equipment furnished and incorporated in the work, including costs of transportation and storage thereof, and Suppliers' field services required in connection therewith. All cash discounts shall accrue to the CONTRACTOR unless the CITY deposits funds with the CONTRACTOR with which to make payments, in which case the cash discounts shall accrue to the CITY. All trade discounts, rebates and refunds and all returns from sale of surplus materials and equipment shall accrue to the CITY, and the CONTRACTOR shall make provisions so that they may be obtained.
- 10.4.3 Payments made by the CONTRACTOR to Subcontractors for work performed by Subcontractors. If required by the CITY, CONTRACTOR shall obtain competitive quotes from Subcontractors or Suppliers acceptable to the CONTRACTOR and shall deliver such quotes to the CITY who will then determine which quotes will be accepted. If a subcontract provides that the Subcontractor is to be paid on the basis of Cost of the Work Plus a Fee, the Subcontractor's Cost of the Work shall be determined in the same manner as the CONTRACTOR's Cost of Work. All subcontracts shall be subject to the other provisions of the Contract Documents insofar as applicable.
- 10.4.4 Costs of special consultants (including but not limited to engineers, architects, testing laboratories, and surveyors) employed for services necessary for the completion of the work.
- 10.4.5 Supplemental costs including the following:
 - a. The proportion of necessary transportation, travel and subsistence expenses of the CONTRACTOR's employees incurred in discharge of duties connected with the work.
 - b. Cost, including transportation and maintenance, of all materials, supplies, equipment, machinery, appliances, office and temporary facilities at the site and hand tools not owned by the workers, which are consumed in the performance of the work, and cost less market value of such items used but not consumed which remain the property of the CONTRACTOR.
 - c. Rentals of all construction equipment and machinery and the parts thereof whether rented from the CONTRACTOR or others in accordance with rental agreements approved by the CITY and the costs of transportation, loading, unloading, installation, dismantling and removal thereof - all in accordance with terms of said rental agreements. The rental of any such equipment, machinery or parts shall cease when the use thereof is no longer necessary for the work.
 - d. Sales, consumer, use or similar taxes related to the work, and for which the CONTRACTOR is liable, imposed by Regulatory Requirements.
 - e. Deposits lost for causes other than negligence of the CONTRACTOR, any Subcontractor or anyone directly or indirectly employed by any of them or for whose acts any of them may be liable, and royalty payments and fees for permits and licenses.

- f. Losses and damages (and related expenses), not compensated by insurance or otherwise, to the Work or otherwise sustained by the CONTRACTOR in connection with the performance and furnishing of the Work provided they have resulted from causes other than the negligence of the CONTRACTOR, any Subcontractor, or anyone directly or indirectly employed by any of them or for whose acts any of them may be liable. Such losses shall include settlements made with the written consent and approval of the CITY. No such losses, damages and expenses shall be included in the Cost of the Work for the purpose of determining the CONTRACTOR's Fee. If, however, any such loss or damage requires reconstruction and the CONTRACTOR is placed in charge thereof, the CONTRACTOR shall be paid for services a fee proportionate to that stated in paragraphs 10.6.2.a and 10.6.2.b.
- g. The cost of utilities, fuel and sanitary facilities at the site.
- h. Minor expenses such as long distance telephone calls, telephone service at the site, expressage and similar petty cash items in connection with the work.
- i. Cost of premiums for additional bonds and insurance required because of changes in the work and premiums for property insurance coverage within the limits of the deductible amounts established by the CITY in accordance with Article 5.

10.5 Excluded Costs:

The term Cost of the Work shall not include any of the following:

- 10.5.1 Payroll costs and other compensation of CONTRACTOR's officer, executives, principals (of partnership and sole proprietorships), general managers, engineers, architects, estimators, attorneys, auditors, accountants, purchasing and contracting agency, expeditors, timekeepers, clerks and other personnel employed by CONTRACTOR whether at the site or in CONTRACTOR's principal or a branch office for general administration of the Work and not specifically included in the agreed upon schedule of job classifications referred to in paragraph 10.4.1 or specifically covered by paragraph 10.4.4 - all of which are to be considered administrative costs covered by the CONTRACTOR's Fee.
- 10.5.2 Expenses of CONTRACTOR's principal and branch offices other than CONTRACTOR's office at the site.
- 10.5.3 Any part of CONTRACTOR's capital expenses including interest on CONTRACTOR's capital employed for the Work and charges against CONTRACTOR for delinquent payments.
- 10.5.4 Cost of premiums for all bonds and for all insurance whether or not CONTRACTOR is required by the Contract Documents to purchase and maintain the same (except for the cost of premiums covered by subparagraph 10.4.5.i above).
- 10.5.5 Costs due to the negligence of CONTRACTOR, any Subcontractor, or anyone directly or indirectly employed by any of them or for whose acts any of them may be liable, including but not limited to, the correction of Defective Work, disposal of materials or equipment wrongly supplied and making good any damage to property.
- 10.5.6 Other overhead or general expense costs of any kind and the costs of any item not specifically and expressly included in paragraph 10.4.

10.6 CONTRACTOR's Fee:

The CONTRACTOR's Fee allowed to CONTRACTOR for overhead and profit shall be determined as follows:

- 10.6.1 A mutually acceptable fixed fee; or if none can be agreed upon.
- 10.6.2 A fee based on the following percentages of the various portions of the Cost of the Work:
 - a. For costs incurred under paragraphs 10.4.1 and 10.4.2, the CONTRACTOR's Fee shall be twenty percent;

- b. For costs incurred under paragraph 10.4.3, the CONTRACTOR's Fee shall be fifteen percent; and if a sub-contract is on the basis of Cost of the Work Plus a Fee, the maximum allowable to CONTRACTOR on account of overhead and profit of all subcontractors shall be fifteen percent;
- c. No fee shall be payable on the basis of costs itemized under paragraphs 10.4.4, 10.4.5 and 10.5;
- d. The amount of credit to be allowed by the CONTRACTOR to the CITY for any such change which results in a net decrease in cost will be the amount of the actual net decrease plus a deduction in CONTRACTOR's Fee by an amount equal to ten percent of the net decrease; and
- e. When both additions and credits are involved in any one change, the adjustment in CONTRACTOR's Fee shall be computed on the basis of the net change in accordance with paragraphs 10.6.2.a through 10.6.2.d, inclusive.

10.7 Cost Breakdown:

Whenever the cost of any work is to be determined pursuant to paragraphs 10.4 and 10.5, the CONTRACTOR will submit in form acceptable to the CITY an itemized cost breakdown together with supporting data.

10.8 Cash Allowances:

It is understood the CONTRACTOR has included in the Contract Price all allowances so named in the Contract Documents and shall cause the Work so covered to be done by such Subcontractors or Suppliers and for such sums within the limit of the allowances as may be acceptable to the Contracting Officer. CONTRACTOR agrees that:

- 10.8.1 The allowances include the cost to CONTRACTOR (less any applicable trade discounts) of materials and equipment required by the allowances to be delivered at the site, and all applicable taxes; and
- 10.8.2 CONTRACTOR's cost for unloading and handling on the site, labor, installation costs, overhead, profit and other expenses contemplated for the allowances have been included in the Contract Price and not in the allowances. No demand for additional payment on account of any thereof will be valid.

Prior to final payment, an appropriate Change Order will be issued to reflect actual amounts due the CONTRACTOR on account of Work covered by allowances, and the Contract Price shall be correspondingly adjusted.

10.9 Unit Price Work:

- 10.9.1 Where the Contract Documents provide that all or part of the Work is to be Unit Price Work, initially the Contract Price will be deemed to include for all Unit Price Work an amount equal to the sum of the established unit prices for each separately identified item of Unit Price Work times the estimated quantity of each item as indicated in the Contract. The estimated quantities of items of Unit Price Work are not guaranteed and are solely for the purpose of comparison of Bids and determining an initial Contract Price. Determinations of the actual quantities and classifications of Unit Price Work performed by the CONTRACTOR will be made by the CITY in accordance with paragraph 10.9.3.
- 10.9.2 Each unit price will be deemed to include an amount considered by the CONTRACTOR to be adequate to cover the CONTRACTOR's overhead and profit for each separately identified item. If the "Basis of Payment" clause in the Contract Documents relating to any unit price in the bid schedule requires that the said unit price cover and be considered compensation for certain work or material essential to the item, this same work or material will not also be measured or paid for under any other pay item which may appear elsewhere in the Contract Documents.
- 10.9.3 Payment to the CONTRACTOR shall be made only for the actual quantities of work performed and accepted or materials furnished, in conformance with the Contract Documents. When the accepted quantities of work or materials vary from the quantities stated in the bid schedule, or change documents, the CONTRACTOR shall accept as payment in full, payment at the stated unit prices for the accepted quantities of work and materials furnished, completed and accepted; except as provided below:

- a. When the quantity of work to be done or material to be furnished under any item, for which the total cost of the item exceeds 10% of the total Contract Price, is increased by more the 25 per cent of the quantity stated in the bid schedule, or change documents, either party to the Contract, upon demand, shall be entitled to an equitable unit price adjustment on the portion of the work above 125 per cent of the quantity stated in the bid schedule.
- b. When the quantity of work to be done or material to be furnished under any major item, for which the total cost of the item exceeds 10% of the total Contract Price, is decreased by more than 25 per cent of the quantity stated in the bid schedule, or change documents either party to the contract, upon demand, shall be entitled to an equitable price adjustment for the quantity of work performed or material furnished, limited to a total payment of not more the 75 per cent of the amount originally bid for the item.

10.10 Determinations for Unit Prices:

The Contracting Officer will determine the actual quantities and classifications of Unit Price Work performed by the CONTRACTOR . The Contracting Officer will review with the CONTRACTOR preliminary determinations on such matters before certifying the prices on the Bid Schedule. The Contracting Officer's certification thereon will be final and binding on the CONTRACTOR, unless, within ten days after the date of any such decisions, the CONTRACTOR delivers to the Contracting Officer written notice of intention to appeal from such a decision.

ARTICLE 11 - CONTRACT TIME; COMPUTATION AND CHANGE

11.1 Commencement of Contract Time; Notice to Proceed:

The Contract Time will commence to run on the day indicated in the Notice to Proceed.

11.2 Starting the Work:

No work on contract items shall be performed before the effective date of the Notice to Proceed. The CONTRACTOR shall notify the Contracting Officer at least 24 hours in advance of the time actual construction operations will begin. The CONTRACTOR may request a limited Notice to Proceed after award has been made, to permit him to order long lead materials which could cause delays in project completion. However, granting is within the sole discretion of the Contracting Officer, and refusal or failure to grant a limited Notice to Proceed shall not be a basis for claiming for delay, extension of time, or alteration of price.

11.3 Computation of Contract Time:

11.3.1 When the contract time is specified on a calendar days basis, all work under the contract shall be completed within the number of calendar days specified. The count of contract time begins on the day following receipt of the Notice to Proceed by the CONTRACTOR, if no starting day is stipulated therein. Calendar days shall continue to be counted against contract time until and including the date of Final Completion of the Work.

11.3.2 When the Contract completion time is specified as a fixed calendar date, it shall be the date of Final Completion.

11.4 Time Change:

The Contract Time may only be changed by a Change Order or Supplemental Agreement.

11.5 Extension Due to Delays:

The right of the CONTRACTOR to proceed shall not be terminated nor the CONTRACTOR charged with liquidated or actual damages because of any delays to the completion of the Work due to unforeseeable causes beyond the control and without the fault or negligence of the CONTRACTOR, including, but not restricted to the following: acts of God or of the public enemy, acts of the CITY in contractual capacity, acts of another contractor in the performance of a contract with the CITY, floods, fires, epidemics, quarantine restrictions, strikes, freight embargoes, unusually severe weather and delays of Subcontractors or Suppliers due to such causes. Any delay in receipt of materials on the site, caused by other than one of the specifically mentioned occurrences above, does not of itself justify a time extension. Provided, that the

CONTRACTOR shall within twenty four (24) hours from the beginning of any such delay (unless the Contracting Officer shall grant a further period of the time prior to the date of final settlement of the Contract) notify the Contracting Officer in writing of the cause of delay. The Contracting Officer shall ascertain the facts and the extent of the delay and extend the time for completing the Work when the findings of fact justify such an extension.

11.6 Essence of Contract:

All time limits stated in the Contract Documents are of the essence of the Contract.

11.7 Reasonable Completion Time:

It is expressly understood and agreed by and between the CONTRACTOR and the CITY that the date of beginning and the time for Final Completion of the Work described herein are reasonable times for the completion of the Work.

11.8 Delay Damages:

Whether or not the CONTRACTOR's right to proceed with the Work is terminated, he and his sureties shall be liable for damages resulting from his refusal or failure to complete the Work within the specified time. Liquidated damages for delay shall be paid by the CONTRACTOR or his Surety to the City in the amount as specified in the Agreement or the Supplementary Conditions for each Calendar Day the completion of the Work or any part thereof is delayed beyond the Contract Time required by the Contract, or any extension thereof. If such amount of liquidated damages is not established by the Contract Documents, then the CONTRACTOR and his Surety shall be liable to the City for any actual damages occasioned by such delay. The CONTRACTOR acknowledges that the liquidated damages established herein are not a penalty but rather constitute an estimate of damages that the City will sustain by reason of delayed completion. These liquidated damages are intended as compensation for losses difficult to estimate, and include those items enumerated in the Supplementary Conditions or elsewhere in the Contract Documents. These damages will continue to run both before and after termination in the event of default termination. These liquidated damages do not cover excess costs of completion or the CITY's costs, fees, and charges related to reprocurement. If a default termination occurs, the Contractor or his Surety shall pay in addition to these damages, all excess costs and expenses related to completion as provided by Article 14.2.5.

ARTICLE 12 - QUALITY ASSURANCE

12.1 Warranty and Guaranty:

The CONTRACTOR warrants and guarantees to the CITY that all Work will be in accordance with the Contract Documents and will not be Defective. Prompt notice of all defects shall be given to the CONTRACTOR. All Defective Work, whether or not in place, may be rejected, corrected or accepted as provided for in this Article.

12.2 Access to Work:

The CITY and the CITY's representatives, testing agencies and governmental agencies with jurisdiction interests will have access to the Work at reasonable times for their observation, inspecting and testing. The CONTRACTOR shall provide proper and safe conditions for such access.

12.3 Tests and Inspections:

12.3.1 The CONTRACTOR shall give the Contracting Officer timely notice of readiness of the Work for all required inspections, tests or approvals.

12.3.2 If Regulatory Requirements require any Work (or part thereof) to specifically be inspected, tested or approved, the CONTRACTOR shall assume full responsibility therefor, pay all costs in connection therewith and furnish the Contracting Officer the required certificates of inspection, testing or approval. The CONTRACTOR shall also be responsible for and shall pay all costs in connection with any inspection or testing required in connection with CITY's acceptance of a Supplier of materials or equipment proposed to be incorporated in the Work, or of materials or equipment submitted for approval prior to the CONTRACTOR's purchase thereof for incorporation in the Work. The cost of all inspections, tests and approvals in addition to the above which are required by the Contract Documents shall be paid by the CONTRACTOR. The CITY

may perform additional tests and inspections which it deems necessary to insure quality control. All such failed tests or inspections shall be at the CONTRACTOR's expense.

12.3.3 If any Work (including the work of others) that is to be inspected, tested or approved is covered without written concurrence of the Contracting Officer, it must, if requested by the Contracting Officer, be uncovered for observation. Such uncovering shall be at the CONTRACTOR's expense unless the CONTRACTOR has given the Contracting Officer timely notice of CONTRACTOR's intention to cover the same and the Contracting Officer has not acted with reasonable promptness in response to such notice.

12.3.4 Neither observations nor inspections, test or approvals by the CITY of others shall relieve the CONTRACTOR from the CONTRACTOR's obligations to perform the Work in accordance with the Contract Documents.

12.4 Uncovering Work:

12.4.1 If any Work is covered contrary to the written request of the Contracting Officer, it must, if requested by the Contracting Officer, be uncovered for the contracting Officer's observation and replaced at the CONTRACTOR's expense.

12.4.2 If the Contracting Officer considers it necessary or advisable that covered Work be observed, inspected or tested, the CONTRACTOR, at the Contracting Officer's request, shall uncover, expose or otherwise make available for observation, inspection or testing as the Contracting Officer may require, that portion of the Work in question, furnishing all necessary labor, material and equipment. If it is found that such Work is Defective, the CONTRACTOR shall bear all direct, indirect and consequential costs of such uncovering, exposure, observation, inspection and testing and of satisfactory reconstruction, (including but not limited to fees and charges of engineers, architects, attorneys and other professionals) and the CITY shall be entitled to an appropriate decrease in the Contract Price. If, however, such Work is not found to be Defective, the CONTRACTOR shall be allowed an increase in the Contract Price or an extension of the Contract Time, or both, directly attributable to such uncovering, exposure, observation, inspection, testing and reconstruction.

12.5 CITY May Stop the Work:

If the Work is Defective, or the CONTRACTOR fails to supply suitable materials or equipment, or fails to furnish or perform the Work in such a way that the completed Work will conform to the Contract Documents, the Contracting Officer may order the CONTRACTOR to stop the Work, or any portion thereof, until the cause for such order has been eliminated; however, this right of the Contracting Officer to stop the Work shall not give rise to any duty on the part of the Contracting Officer to exercise this right for the benefit of the CONTRACTOR.

12.6 Correction or Removal of Defective Work:

If required by the Contracting Officer, the CONTRACTOR shall promptly, as directed, either correct all Defective Work, whether or not fabricated, installed or completed, or, if the Work has been rejected by the Contracting Officer, remove it from the site and replace it with Work which conforms to the requirements of the Contract Documents. The CONTRACTOR shall bear all direct, indirect and consequential costs of such correction or removal (including but not limited to fees and charges of engineers, architects, attorneys and other professionals) made necessary thereby.

12.7 One Year Correction Period:

If within one year after the date of Final Completion or such longer period of time as may be prescribed by Regulatory Requirements or by the terms of any applicable special guarantee required by the Contract Documents or by any specific provision of the Contract Documents, any Work is found to be Defective, the CONTRACTOR shall promptly, without cost to the CITY and in accordance with the Contracting Officer's written instructions, either correct such Defective Work, or, if it has been rejected by the Contracting Officer, remove it from the site and replace it with conforming Work. If the CONTRACTOR does not promptly comply with the terms of such instructions, or in an emergency where delay would cause serious risk of loss or damage, the CITY may have the Defective Work corrected or the rejected Work removed and replaced, and all direct, indirect and consequential costs of such removal and replacement (including but not limited to fees and charges of engineers, architects, attorneys and other professionals) will be paid by the CONTRACTOR. In special circumstances where a particular item of equipment is placed in continuous service for the benefit of the CITY before Substantial Completion of all the Work, the correction period for the item may begin on an

earlier date if so provided in the Specifications or by Change Order. Provisions of this paragraph are not intended to shorten the Statute of Limitations for bringing an action.

12.8 Acceptance of Defective Work:

Instead of requiring correction or removal and replacement of Defective Work, the Contracting Officer may accept Defective Work, the CONTRACTOR shall bear all direct, indirect and consequential costs attributable to the Contracting Officer's evaluation of and determination to accept such Defective Work (costs to include but not be limited to fees and charges of engineers, architects, attorneys and other professionals). If any such acceptance occurs prior to final payment, a Change Order will be issued incorporating the necessary revisions in the Contract Documents with respect to the Work; and the CITY shall be entitled to an appropriate decrease in the Contract Price. If the CITY has already made final payment to the CONTRACTOR, an appropriate amount shall be paid by the CONTRACTOR or his Surety to the CITY.

12.9 CITY May Correct Defective Work:

If the CONTRACTOR fails within a reasonable time after written notice from the Contracting Officer to proceed to correct Defective Work or to remove and replace rejected Work as required by the Contracting Officer in accordance with paragraph 12.6, or if the CONTRACTOR fails to perform the Work in accordance with the Contract Documents, or if the CONTRACTOR fails to comply with any other provision of the Contract Documents, the CITY may, after seven days' written notice to the CONTRACTOR, correct and remedy any such deficiency. In exercising the rights and remedies under this paragraph the CITY shall proceed expeditiously. To the extent necessary to complete corrective and remedial action, the Contracting Officer may exclude the CONTRACTOR from all or part of the site, take possession of all or part of the Work, and suspend the CONTRACTOR's services related thereto, take possession of the CONTRACTOR's tool, appliances, construction equipment and machinery at the site and incorporate in the Work all materials and equipment stored at the site or approved remote storage sites or for which the CITY has paid the CONTRACTOR but which are stored elsewhere, the CONTRACTOR shall allow the Contracting Officer and his authorized representatives such access to the site as may be necessary to enable the Contracting Officer to exercise the rights and remedies under this paragraph. All direct, indirect and consequential costs of the CITY or its agents in exercising such rights and remedies will be charged against the CONTRACTOR, and a Change Order will be issued incorporating the necessary revisions in the Contract Documents with respect to the Work; and the CITY shall be entitled to an appropriate decrease in the Contract Price. Such direct, indirect and consequential costs will include but not be limited to fees and charges of engineers, architects, attorneys and other professionals, all court and arbitration costs and all cost of repair and replacement of work of others destroyed or damaged by correction, removal or replacement of the CONTRACTOR's Defective Work. The CONTRACTOR shall not be allowed an extension of the Contract Time because of any delay in performance of the Work attributable to the exercise by the Contracting Officer of the CITY's rights and remedies hereunder.

ARTICLE 13 - PAYMENTS TO CONTRACTOR AND COMPLETION

13.1 Schedule of Values:

The Schedule of Values established as provided in paragraph 6.6 will serve as the basis for progress payments and will be incorporated into a form of Application for Payment acceptable to the Contracting Officer. Progress payments on account of Unit Price Work will be based on the number of units completed.

13.2 Preliminary Payments:

Upon approval of the Schedule of Values the CONTRACTOR may be paid for direct costs substantiated by paid invoices and other prerequisite documents required by the General Requirements. Direct costs shall include the cost of Bonds, insurance, approved materials stored on the site or at approved remote storage sites, deposits required by a Supplier prior to fabricating materials, and other approved direct mobilization costs substantiated as indicated above. These payments shall be included as a part of the total Contract Price as stated in the Contract.

13.3 Application for Progress Payment:

The CONTRACTOR shall submit to the Contracting Officer for review an Application for Payment filled out and signed by the CONTRACTOR covering the Work completed as of the date of the Application for Payment and accompanied by such supporting documentation as is required by the Contract Documents. Progress payments will be made as the Work progresses on a monthly basis or twice a month when requested by the CONTRACTOR, but only when the approved invoice exceeds \$10,000.00.

13.4 Review of Applications for Progress Payments:

Contracting Officer will, either indicate in writing a recommendation of payment, or return the Application for Payment to the CONTRACTOR indicating in writing the Contracting Officer's reasons for refusing to recommend payment. If the latter case, the CONTRACTOR may make the necessary corrections and resubmit the Application for Payment.

13.5 Stored Materials and Equipment:

If payment is requested on the basis of materials and equipment not incorporated in the Work but delivered and suitably stored at the site or at another location agreed to in writing, the Application for Payment shall also be accompanied by a bill of sale, invoice or other documentation warranting that the CITY has received the materials and equipment free and clear of all charges, security interests and encumbrances and evidence that the materials and equipment are covered by appropriate property insurance and other arrangements to protect the CITY's interest therein, all of which will be satisfactory to the Contracting Officer. No payment will be made for perishable materials that could be rendered useless because of long storage periods. No progress payment will be made for living plant materials until planted. The payment may be reduced by an amount equal to transportation and handling cost if the materials are stored offsite, in a remote location, or will require special handling.

13.6 CONTRACTOR's Warranty of Title:

The CONTRACTOR warrants and guarantees that title to all Work, materials and equipment covered by any Application for Payment, whether incorporated in the Project or not, will pass to the CITY no later than the time of payment free and clear of any claims, liens, security interests and further obligations.

13.7 Withholding of Payments:

The CITY may withhold or refuse payment for any of the reasons listed below provided it gives written notice of its intent to withhold and of the basis for withholding:

- 13.7.1 The Work is Defective, or completed Work has been damaged requiring correction or replacement, or has been installed without approval of Shop Drawing, or by an unapproved Subcontractor.
- 13.7.2 The Contract Price has been reduced by Change Order.
- 13.7.3 The CITY has been required to correct Defective Work or complete Work in accordance with paragraph 12.9.
- 13.7.4 The CITY's actual knowledge of the occurrence of any of the events enumerated in paragraphs 14.2.1.a through 14.2.1.k inclusive.
- 13.7.5 Claims have been made against the CITY or against the funds held by the CITY on account of the CONTRACTOR's actions or inactions in performing this Contract, or there are other items entitling the CITY to a set off.
- 13.7.6 Subsequently discovered evidence or the results of subsequent inspections or test, nullify any previous payments for reasons stated in subparagraphs 13.7.1 through 13.7.5.
- 13.7.7 The CONTRACTOR has failed to fulfill or is in violation of any of his obligations under any provision of this Contract.

13.8 Retainage:

At any time the CITY finds that satisfactory progress is not being made it may in addition to the amounts withheld under 13.7 retain a maximum amount equal to 10% of the total amount earned on all subsequent progress payments. This retainage may be released at such time as the Contracting Officer finds that satisfactory progress is being made.

13.9 Request for Release of Funds:

If the CONTRACTOR believes the basis for withholding is invalid or no longer exists, immediate written notice of the facts and Contract provisions on which the CONTRACTOR relies, shall be given to the CITY, together with a request for release of funds and adequate documentary evidence proving that the problem has been cured. In the case of withholding which has occurred at the request of the Department of Labor and Workforce Development, the CONTRACTOR shall provide a letter from the Department of Labor stating that withholding is no longer requested. Following such a submittal by the CONTRACTOR, the CITY shall have a reasonable time to investigate and verify the facts and seek additional assurances before determining whether release of withheld payments is justified.

13.10 Substantial Completion:

When the CONTRACTOR considers the Work ready for its intended use the CONTRACTOR shall notify the Contracting Officer in writing that the Work or a designated portion thereof is substantially complete (except for items specifically listed by the CONTRACTOR as incomplete) and request that the CITY issue a certificate of Substantial Completion. Within a reasonable time thereafter, the Contracting Officer, the CONTRACTOR and appropriate Consultant(s) shall make an inspection of the Work to determine the status of completion. If the Contracting Officer does not consider the Work substantially complete, the Contracting Officer will notify the CONTRACTOR in writing giving the reasons therefor. If the Contracting Officer considers the Work substantially complete, the Contracting Officer will within fourteen days execute and deliver to the CONTRACTOR a certificate of Substantial Completion with tentative list of items to be completed or corrected. At the time of delivery of the certificate of Substantial Completion the Contracting Officer will deliver to the CONTRACTOR a written division of responsibilities pending Final Completion with respect to security, operation, safety, maintenance, heat, utilities, insurance and warranties which shall be consistent with the terms of the Contract Documents. The CITY shall be responsible for all CITY costs resulting from the initial inspection and the first re-inspection, the CONTRACTOR shall pay all costs incurred by the CITY resulting from re-inspections, thereafter.

13.11 Access Following Substantial Completion:

The CITY shall have the right to exclude the CONTRACTOR from the Work after the date of Substantial Completion, but the CITY shall allow CONTRACTOR reasonable access to complete or correct items on the tentative list.

13.12 Final Inspection:

Upon written notice from the CONTRACTOR that the entire Work or an agreed portion thereof is complete, the Contracting Officer will make a final inspection with the CONTRACTOR and appropriate Consultants and will notify the CONTRACTOR in writing of all particulars in which this inspection reveals that the Work is incomplete or Defective. The CONTRACTOR shall immediately take such measures as are necessary to remedy such deficiencies. The CONTRACTOR shall pay for all costs incurred by the CITY resulting from re-inspections.

13.13 Final Application for Payment:

After the CONTRACTOR has completed all such corrections to the satisfaction of the Contracting Officer and delivered all maintenance and operating instructions, schedules, guarantees, bonds, certificates of payment to all laborers, Subcontractors and Suppliers, certificates of inspection, marked-up record documents and other documents - all as required by the Contract Documents, and after the Contracting Officer has indicated that the Work is acceptable (subject to the provisions of paragraph 13.17), the CONTRACTOR may make application for final payment following the procedure for progress payments. The final Application for Payment shall be accompanied by all certificates, warranties, guaranties, releases, affidavits, and other documentation required by the Contract Documents.

13.14 Final Payment and Final Completion:

- 13.14.1 If on the basis of the Contracting Officer's observation of the Work during construction and final inspection, and the Contracting Officer's review of the final Application for Payment and accompanying documentation - all as required by the Contract Documents, the Contracting Officer is satisfied that the Work has been completed and the CONTRACTOR's other obligations under the Contract Documents have been fulfilled, the CITY will process final Application for Payment. Otherwise, the Contracting Officer will return the Application for Payment to the CONTRACTOR, indicating in writing the reasons for refusing to process final payment, in which case the CONTRACTOR shall make the necessary corrections and resubmit the final Application for Payment.

13.14.2 If, through no fault of the CONTRACTOR, Final Completion of the Work is significantly delayed, the Contracting Officer shall, upon receipt of the CONTRACTOR's final Application for Payment, and without terminating the Contract, make payment of the balance due for that portion of the Work fully completed and accepted. If the remaining balance to be held by the CITY for Work not fully completed or corrected is less than the retainage provided for in paragraph 13.8, and if Bonds have been furnished as required in paragraph 5.1, the written consent of the Surety to the payment of the balance due for that portion of the Work fully completed and accepted shall be submitted by the CONTRACTOR to the CITY with the application for such payment. Such payment shall be made under the terms and conditions governing final payment, except that it shall not constitute a waiver of claims.

13.14.3 In addition to other requirements, final payment shall not be due until CITY's receipt of verification from the State of Alaska Department of Labor and Workforce Development ("the Department") that (i) Contractor has complied with AS 36.05.045(a) and (ii) the Department is not conducting an investigation and (iii) the Department has not issued a notice of violation of AS 36.05 to Contractor or to any subcontractor.

13.15 Final Acceptance:

Following receipt of the CONTRACTOR's Release with no exceptions, and certification that laborers, Subcontractors and materialmen have been paid, certification of payment of payroll and sales taxes and revenue taxes, and final payment to the CONTRACTOR, the CITY will issue a letter of Final Acceptance, releasing the CONTRACTOR from further obligations under the Contract, except as provided in paragraph 13.16.

13.16 CONTRACTOR's Continuing Obligation:

The CONTRACTOR's obligation to perform and complete the Work and pay all laborers, Subcontractors, and materialmen in accordance with the Contract Documents shall be absolute. Neither any progress or final payment by the CITY, nor the issuance of a certificate of Substantial Completion, nor any use or occupancy of the Work or any part thereof by the CITY, nor any act of acceptance by the CITY nor any failure to do so, nor any review and approval of a Shop Drawing or sample submission, nor any correction of Defective Work by the CITY will constitute an acceptance of Work not in accordance with the Contract Documents or a release of the CONTRACTOR's obligation to perform the Work in accordance with the Contract Documents.

13.17 Waiver of Claims by CONTRACTOR:

The making and acceptance of final payment will constitute a waiver of all claims by the CONTRACTOR against the CITY other than those previously made in writing and still unsettled.

13.18 No Waiver of Legal Rights:

The CITY shall not be precluded or be stopped by any payment, measurement, estimate, or certificate made either before or after the completion and acceptance of the Work and payment therefor, from showing the true amount and character of the Work performed and materials furnished by the CONTRACTOR, nor from showing that any payment, measurement, estimate or certificate is untrue or is incorrectly made, or that the Work or materials are Defective. The CITY shall not be precluded or stopped, notwithstanding any such measurement, estimate, or certificate and payment in accordance therewith, from recovering from the CONTRACTOR or his Sureties, or both, such damages as it may sustain by reason of his failure to comply with requirements of the Contract Documents. Neither the acceptance by the CITY, or any representative of the CITY, nor any payment for or acceptance of the whole or any part of the Work, nor any extension of the Contract Time, nor any possession taken by the CITY, shall operate as a waiver of any portion of the Contract, or of the power herein reserved, or of any right to damages. A waiver by the CITY of any breach of the Contract shall not be held to be a waiver of any other subsequent breach.

ARTICLE 14 - SUSPENSION OF WORK, DEFAULT AND TERMINATION

14.1 CITY May Suspend Work:

14.1.1 The CITY may, at any time suspend the Work or any portion thereof by notice in writing to the CONTRACTOR. If the Work is suspended without cause the CONTRACTOR shall be allowed an increase in the Contract Price or an extension of the Contract Time, or both, directly attributable to any suspension if the CONTRACTOR makes an approved claim therefor as provided in Article 15. However, no adjustment shall

be made under this clause for any suspension, delay, or interruption to the extent that suspension is due to the fault or negligence of the CONTRACTOR, or that suspension is necessary for Contract compliance, or that performance would have been so suspended, delayed, or interrupted by any other cause, including the fault or negligence of the CONTRACTOR.

14.1.2 In case of suspension of Work, the CONTRACTOR shall be responsible for preventing damage to or loss of any of the Work already performed and of all materials whether stored on or off the site or approved remote storage sites.

14.2 Default of Contract:

14.2.1 If the CONTRACTOR:

- a. Fails to begin the Work under the Contract within the time specified in the "Proposal", or
- b. Fails to perform the Work in accordance with the Contract Documents (including, but not limited to, failure to supply sufficient skilled workmen or suitable materials or equipment or failure to adhere to the progress schedule established under paragraph 6.6 as revised from time to time), or
- c. Performs the Work unsuitably or neglects or refuses to remove materials or to correct Defective Work.
- d. Discontinues the prosecution of the Work, or
- e. Fails to resume Work which has been discontinued within a reasonable time after notice to do so, or
- f. Becomes insolvent or is declared bankrupt, or commits any act of bankruptcy or insolvency except as prohibited by 11 U.S.C. 363e, or
- g. Allows any final judgment to stand against him unsatisfied for period of 60 days, or
- h. Makes an assignment for the benefit of creditors without the consent of the Contracting Officer, or
- i. Disregards Regulatory Requirements, or
- j. Otherwise violates in any substantial way any provisions of the Contract Documents, or
- k. For any cause whatsoever, fails to carry on the Work in an acceptable manner, the Contracting Officer may give notice in writing to the CONTRACTOR and his Surety of such delay, neglect, or default.

If the CONTRACTOR or Surety, within the time specified in the above Notice of Default, shall not proceed in accordance therewith, then the CITY may, upon written notification from the Contracting Officer of the fact of such delay, neglect or default and the CONTRACTOR's failure to comply with such notice, have full power and authority without violating the Contract, to take the prosecution of the Work out of the hands of the CONTRACTOR. The CITY may terminate the services of the CONTRACTOR, exclude the CONTRACTOR from the site and take possession of the Work and of all the CONTRACTOR's tools, appliances, construction equipment and machinery at the site and use the same to the full extent they could be used by the CONTRACTOR (without liability to the CONTRACTOR for trespass or conversion), incorporate in the Work all materials and equipment stored at the site or for which the CITY has paid the CONTRACTOR but which are stored elsewhere, and finish the Work as the CITY may deem expedient. The CITY may enter into an agreement for the completion of said Contract according to the terms and provisions thereof, or use such other methods that in the opinion of the Contracting Officer are required for the completion of said Contract in an acceptable manner.

14.2.3 The Contracting Officer may, by written notice to the CONTRACTOR and his Surety or his representative, transfer the employment of the Work from the CONTRACTOR to the Surety, or if the CONTRACTOR abandons the Work undertaken under the Contract, the Contracting Officer may, at his option with written notice to the Surety and without any written notice to the CONTRACTOR, transfer the employment for said Work directly to the Surety. The Surety shall submit its plan for completion of the Work, including any

contracts or agreements with third parties for such completion, to the CITY for approval prior to beginning completion of the Work. Approval of such contracts shall be in accordance with all applicable requirements and procedures for approval of subcontracts as stated in the Contract Documents.

- 14.2.4 Upon receipt of the notice terminating the services of the CONTRACTOR, the Surety shall enter upon the premises and take possession of all materials, tools, and appliances thereon for the purpose of completing the Work included under the Contract and employ by contract or otherwise any person or persons to finish the Work and provide the materials therefor, without termination of the continuing full force and effect of this Contract. In case of such transfer of employment to the Surety, the Surety shall be paid in its own name on estimates covering Work subsequently performed under the terms of the Contract and according to the terms thereof without any right of the CONTRACTOR to make any claim for the same or any part thereof.
- 14.2.5 If the Contract is terminated for default, the CONTRACTOR and the Surety shall be jointly and severally liable for damages for delay as provided by Article 11.8, and for the excess cost of completion, and all costs and expenses incurred by the CITY in completing the Work or arranging for completion of the Work, including but not limited to costs of assessing the Work to be done, costs associated with advertising, soliciting or negotiating for bids or proposals for completion, and other procurement costs. Following termination the CONTRACTOR shall not be entitled to receive any further balance of the amount to be paid under the contract until the work is fully finished and accepted, at which time if the unpaid balance exceeds the amount due the CITY and any amounts due to persons for whose benefit the CITY has withheld funds, such excess shall be paid by the CITY to the CONTRACTOR. If the damages, costs, and expenses due the CITY exceed the unpaid balance, the CONTRACTOR and his Surety shall pay the difference.
- 14.2.6 If, after notice of termination of the CONTRACTOR's right to proceed under the provisions of this clause, it is determined for any reason that the CONTRACTOR was not in default under the provisions of this clause, or that the delay was excusable under the provisions of this clause, or that termination was wrongful, the rights and obligations of the parties shall be determined in accordance with the clause providing for convenience termination.

14.3 Rights or Remedies:

Where the CONTRACTOR's services have been so terminated by the CITY, the termination will not affect any rights or remedies of the CITY against the CONTRACTOR then existing or which may thereafter accrue. Any retention or payment of moneys due the CONTRACTOR by the CITY will not release the CONTRACTOR from liability.

14.4 Convenience Termination:

- 14.4.1 The performance of the Work may be terminated by the CITY in accordance with this section in whole or in part, whenever, for any reason the Contracting Officer shall determine that such termination is in the best interest of the CITY. Any such termination shall be effected by delivery to the CONTRACTOR of a Notice of Termination, specifying termination is for the convenience of the CITY the extent to which performance of Work is terminated, and the date upon which such termination becomes effective. Immediately upon receipt of a Notice of Termination and except as otherwise directed by the Contracting Officer the CONTRACTOR shall:
- a. Stop Work on the date and to the extent specified in the Notice of Termination;
 - b. Place no further orders or subcontracts for materials, services, or facilities except as may be necessary for completion of such portion of the Work as is not terminated;
 - c. Terminate all orders and subcontracts to the extent that they relate to the performance of Work terminated by the Notice of Termination;
 - d. With the written approval of the Contracting Officer, to the extent he may require, settle all outstanding liabilities and all claims arising out of such termination of orders and subcontracts, the cost of which would be reimbursable, in whole, or in part, in accordance with the provisions of the Contract;

- e. Submit to the Contracting Officer a list, certified as to quantity and quality, of any or all items of termination inventory exclusive of items the disposition of which had been directed or authorized by the Contracting Officer;
- f. Transfer to the Contracting Officer the completed or partially completed record drawings, Shop Drawings, information, and other property which, if the Contract had been completed, would be required to be furnished to the CITY;
- g. Take such action as may be necessary, or as the Contracting Officer may direct, for the protection and preservation of the property related to the Contract which is in the possession of the CONTRACTOR and in which the CITY has or may acquire any interest. The CONTRACTOR shall proceed immediately with the performance of the above obligations.

14.4.2 When the CITY orders termination of the Work effective on a certain date, all Work in place as of that date will be paid for in accordance with the Basis of Payment clause of the Contract. Materials required for completion and on hand but not incorporated in the Work will be paid for at cost plus 15% with materials becoming the property of the CITY - or the CONTRACTOR may retain title to the materials and be paid an agreed upon lump sum. Materials on order shall be canceled, and the CITY shall pay reasonable factory cancellation charges with the option of taking delivery of the materials in lieu of payment of cancellation charges. The CONTRACTOR shall be paid 10% of the cost, freight not included, of materials canceled, and direct expenses only for CONTRACTOR chartered freight transport which cannot be canceled without charges, to the extent that the CONTRACTOR can establish them. The extra costs due to cancellation of Bonds and insurance and that part of job start-up and phase-out costs not amortized by the amount of Work accomplished shall be paid by the CITY. Charges for loss of profit or consequential damages shall not be recoverable except as provided above.

14.4.3 The termination claim shall be submitted promptly, but in no event later than 90 days from the effective date of termination, unless one or more extensions in writing are granted by the Contracting Officer upon request of the CONTRACTOR made in writing within the 90-day period. Upon failure of the CONTRACTOR to submit his termination claim within the time allowed, the Contracting Officer may determine, on the basis of information available to him, the amount, if any, due to the CONTRACTOR by reason of the termination and shall thereupon pay to the CONTRACTOR so determined.

14.4.4 The CONTRACTOR and the Contracting Officer may agree upon whole or any part of the amount or amounts to be paid to the CONTRACTOR by reason of the total or partial termination of the Work pursuant to this section. The Contract shall be amended accordingly, and the CONTRACTOR shall be paid the agreed amount. In the event of the failure of the CONTRACTOR and the Contracting Officer to agree in whole or in part, as provided heretofore, as to the amounts with respect to costs to be paid to the CONTRACTOR in connection with the termination of the Work the Contracting Officer shall determine, on the basis of information available to him, the amount, if any, due to the CONTRACTOR by reason of the termination and shall pay to the CONTRACTOR the amount determined as follows:

- a. All costs and expenses reimbursable in accordance with the Contract not previously paid to the CONTRACTOR for the performance of the Work prior to the effective date of the Notice of Termination;
- b. So far as not included under "a" above, the cost of settling and paying claims arising out of the termination of the Work under subcontracts or orders which are properly chargeable to the terminated portions of the Contract;
- c. The reasonable costs of settlement with respect to the terminated portion of the Contract heretofore, to the extent that these costs have not been covered under the payment provisions of the Contract.

14.4.5 The CONTRACTOR shall have the right of appeal under the CITY's claim procedures, as defined in Article 15, for any determination made by the Contracting Officer, except if the CONTRACTOR has failed to submit his claim within the time provided and has failed to request extension of such time, CONTRACTOR shall have no such right of appeal. In arriving at the amount due the CONTRACTOR under this section, there shall be deducted:

- a. All previous payments made to the CONTRACTOR for the performance of Work under the Contract prior to termination;
- b. Any claim which the CITY may have against the CONTRACTOR;
- c. The agreed price for, or the proceeds of sale of, any materials, supplies, or other things acquired by the CONTRACTOR or sold pursuant to the provisions of this section and not otherwise recovered by or credited to the CITY; and,
- d. All progress payments made to the CONTRACTOR under the provisions of this section.

14.4.6 Where the Work has been terminated by the CITY said termination shall not affect or terminate any of the rights of the CITY against the CONTRACTOR or his Surety then existing or which may thereafter accrue because of such default. Any retention or payment of monies by the CITY due to the CONTRACTOR under the terms of the Contract shall not release the CONTRACTOR or his Surety from liability. Unless otherwise provided for in the Contract Documents, or by applicable statute, the CONTRACTOR, from the effective date of termination and for a period of three years after final settlement under this Contract, shall preserve and make available to the CITY at all reasonable times at the office of the CONTRACTOR, all its books, records, documents, and other evidence bearing on the cost and expenses of the CONTRACTOR under his Contract and relating to the Work terminated hereunder.

ARTICLE 15 - CLAIMS AND DISPUTES

15.1 Notification:

In addition to the notice requirements set out elsewhere in this Contract, if the CONTRACTOR becomes aware of any act or occurrence which may form the basis of a claim by the CONTRACTOR for additional compensation or an extension of time for performance, or if any dispute arises regarding a question of fact or interpretation of the contract, the CONTRACTOR shall immediately inform the Project Manager. If the matter cannot be resolved by agreement within 7 days, the CONTRACTOR shall, within the next 14 days, submit an Intent to Claim in writing to the Project Manager. The Claim, if not resolved, shall be presented to the Project Manager, in writing, within 60 days following receipt of the Intent to Claim. Receipt of the Claim will be acknowledged in writing by the Project Manager. The CONTRACTOR agrees that unless these written notices are provided, the CONTRACTOR will have no entitlement to additional time or compensation for such act, event or condition. The CONTRACTOR shall in any case continue diligent performance of the Contract.

15.2 Presenting Claim:

The Claim shall specifically include the following:

- 15.2.1 The act, event or condition giving rise to the claim.
- 15.2.2 The Contract provisions which apply to the claim and under which relief is provided.
- 15.2.3 The item or items of Contract Work affected and how they are affected.
- 15.2.4 The specific relief requested, including contract time if applicable, and the basis upon which it was calculated.

15.3 Claim Validity, Additional Information, and Project Manager's Actions:

The Claim, in order to be valid, must not only show that the CONTRACTOR suffered damages or delay but that those conditions were actually a result of the act, event or condition complained of and that the Contract provides entitlement to relief to the CONTRACTOR for such act, event, or condition. The Project Manager reserves the right to make written request to the CONTRACTOR at any time for additional information which the CONTRACTOR may possess relative to the Claim. The CONTRACTOR agrees to provide the Project Manager such additional information within 30 days of receipt of such a request. Failure to furnish such additional information may be regarded as a waiver of the Claim. The Claim, if not resolved by agreement within 60 days of its receipt, will automatically be forwarded to the Contracting Officer for formal written decision.

15.4 Contracting Officer's Decision:

The CONTRACTOR will be furnished the Contracting Officer's Decision within the next 90 days, unless additional information is requested by the Contracting Officer. The Contracting Officer's Decision is final and conclusive unless fraudulent as to the Claim.

15.5 Notice of Appeal:

Within 30 days of receipt of the Decision, the CONTRACTOR may deliver a Notice of Appeal to the City Manager of Unalaska, Alaska. The Notice of Appeal shall include specific exceptions to the Contracting Officer's Decision, including specific provisions of the contract, which the CONTRACTOR intends to rely upon in the appeal. General assertions that the Contracting Officer's decision is contrary to law or fact are not sufficient.

15.6 City Manager's Decision:

The decision of the City Manager will be rendered within 120 days of Notice of Appeal. This decision constitutes the exhaustion of contractual and administrative remedies. The time limits given above may only be extended by mutual consent. The decision of the City Manager shall be final and conclusive unless the CONTRACTOR commences action through the court within 120 days from receipt thereof.

Section 00800
SUPPLEMENTARY CONDITIONS

REFERENCE: 1. "GENERAL CONDITIONS OF THE CONTRACT", constitutes the General Conditions of this Contract and is further revised and supplemented by the provisions of these Supplementary Conditions to the Contract, hereinafter called the "Supplementary Conditions." The General Conditions and the Supplementary Conditions are applicable to all of the Work under this Contract and shall apply to the Contractor and all Subcontractors.

SUPPLEMENTS: 2. The following supplements modify, change, delete, or add to the General Conditions. Where any article of the General Conditions is modified or any paragraph, subparagraph or clause thereof is modified, or deleted by these supplements, the unaltered provisions of such article, paragraph, subparagraph or clause shall remain in effect.

SC-1 ARTICLE 1 - DEFINITIONS, Add the following:

OWNER - The OWNER and CONTRACTING OFFICER are further defined as:

City of Unalaska
Department of Public Works
P.O. Box 610
Unalaska, Alaska 99685-0610
Tel. (907) 581-1260
FAX (907) 581-2187

ENGINEER - The ENGINEER is further defined as:

PND Engineers, Inc.
1506 W. 36th Ave.
Anchorage, AK 99503
Tel. (907) 561-1011
FAX (907) 563-4220

SC-2 ARTICLE 4 - LANDS AND PHYSICAL CONDITIONS

4.3 No subsurface investigation was conducted for this project.

SC-3 ARTICLE 4 - LANDS AND PHYSICAL CONDITIONS, Add the following section:

“4.8 HAZARDOUS MATERIALS

A. OWNER shall be responsible for any Asbestos, PCB's, Petroleum, Hazardous Waste, or Radioactive Material uncovered or revealed at the site which was not shown or indicated in Drawings or Specifications or identified in the Contract Documents to be within the scope of WORK and which may present a substantial danger to persons or property exposed thereto in connection with the WORK at the site. OWNER will not be responsible for any such material brought to the site by the CONTRACTOR, Subcontractors, Suppliers, or anyone else for whom CONTRACTOR is responsible.

- B. CONTRACTOR shall immediately stop all WORK in connection with such hazardous condition and any area affected thereby (except in an emergency as required in the General Conditions) and notify OWNER and ENGINEER (and thereafter confirm such notice in writing.) OWNER will promptly consult with ENGINEER concerning the necessity for OWNER to retain a qualified expert to evaluate such hazardous condition or take corrective action, if any. CONTRACTOR shall not be required to resume WORK in connection with such hazardous condition or in any such affected area until after OWNER has obtained any required permits related thereto, and delivered to CONTRACTOR special written notice. Such written notice will specify that such condition and any affected area is or has been rendered safe for resumption of the WORK or specify any special conditions under which such WORK may be resumed safely. If OWNER and CONTRACTOR cannot agree as to entitlement to or the amount or extent of adjustment, if any, in Contract Price or Contract Times as a result of such WORK stoppage or such special conditions under which WORK is agreed by CONTRACTOR to be resumed, either party may make a claim therefor and provided in Articles 10 and 11.”

SC-4 ARTICLE 11 - CONTRACT TIME; COMPUTATION AND CHANGE

- 11.2 Starting the Work; Change the second sentence to read as follows:

“CONTRACTOR shall notify the Contracting Officer at least fourteen (14) days in advance of the time actual construction operations will begin.”

SC-5 ARTICLE 11 - CONTRACT TIME; COMPUTATION AND CHANGE

- 11.5 Extension Due to Delays; Add the following sentence:

“Normal weather in Unalaska shall not be cause for time extension and the CONTRACTOR shall allow ample time in his schedule to accommodate normal weather delays.”

SC-6 ARTICLE 13 – PAYMENTS TO CONTRACTOR AND COMPLETION

- 13.3 Application for Progress Payment; add the following:

13.3.2 The Contractor is required to submit a copy of the current red-lined as-built construction drawings with each monthly pay application. The City may withhold payment from the Contractor if the submitted as-builts are not current or are not in accordance with the General Notes of the contract drawings and all related contract documents.

SC-7 ARTICLE 13 – PAYMENTS TO CONTRACTOR AND COMPLETION

- 13.8 Retainage:

Delete the existing paragraph and replace with the following:

“The CITY will retain a maximum amount equal to 10% of the total amount earned on all progress payments. Once 50 percent of the work is complete and if the character and progress of the work have been satisfactory to the City, the City may determine that, as long as the character and progress of the work remain satisfactory to them, there will be no additional retainage on account of work completed; in which case, the remaining progress payments prior to Substantial

Completion will be in an amount equal to 100 percent of the work completed. All retainage shall bear interest at the rate required by AS 36.90.250”

SC-8 ARTICLE 13 – PAYMENTS TO CONTRACTOR AND COMPLETION

13.14 Final Payment and Final Completion; add the following:

13.14.4 The CONTRACTOR shall furnish the following forms fully executed prior to the City making final payment: Affidavit of Release of Liens by the Contractor, Lien Release Form, and Lien Release General to City. The forms will be made available to the CONTRACTOR in electronic format near the end of the project.

SC-9 ARTICLE 3 – CONTRACT DOCUMENTS: INTENT, AMENDING, REUSE

3.2 Copies of Contract Documents:

Change the paragraph to read: “The CITY shall furnish the CONTRACTOR up to four copies of the Contract Documents. Additional copies will be furnished, upon request, at the cost of reproduction.”

SC-10 ARTICLE 6 – CONTRACTOR’S RESPONSIBILITIES

Add the following sections:

6.14 Use of Premises; add the following sentence:

“It is the responsibility of the CONTRACTOR to obtain all required staging area for the project.”

6.17 Safety and Protection; add the following:

6.17.4 The CONTRACTOR shall do whatever work is necessary for overall project safety and be solely and completely responsible for affected conditions of the job site, including safety of all persons (including employees) and property during the Contract period. This requirement shall apply continuously and is not limited to normal working hours.

Safety provisions shall conform to Federal and State Departments of Labor Occupational Safety and Health Act (OSHA), and other applicable federal, state, county, and local laws, ordinances, codes, requirements set forth herein, and regulations that may be specified in other parts of these Contract Documents. Where these are in conflict, the more stringent requirements shall apply. CONTRACTOR shall become thoroughly familiar with governing safety provisions and shall comply with the obligations set forth therein.

The CONTRACTOR shall develop and maintain for the duration of the Contract, a safety program that will effectively incorporate and implement required safety provisions. CONTRACTOR shall appoint a qualified employee who is authorized to supervise and enforce compliance with the safety program.

The Contracting Officer’s duty to conduct construction review of the CONTRACTOR’s performance does not include a review or approval of the adequacy of

CONTRACTOR's safety supervisor, safety program, or safety measures taken in, on, or near the construction site.

As part of safety program, CONTRACTOR shall maintain at its office or other well-known location at the job site, safety equipment applicable to the Work as prescribed by governing safety authorities, and articles necessary for giving first aid to the injured. CONTRACTOR shall establish procedures for the immediate removal to a hospital or a doctor's care of persons who may be injured on the job site.

CONTRACTOR shall do all work necessary to protect the general public from hazards, including but not limited to, surface irregularities, trenches, excavations, traffic control and blasting. Barricades, lanterns, temporary lighting and proper signs shall be furnished in sufficient amount to safeguard the public and the work. CONTRACTOR shall construct and maintain satisfactory and substantial fencing, railings, barricades, or steel plates, as applicable, at all openings, obstructions, or other hazards. Such barricades shall have adequate warning lights as necessary or required for safety.

- 6.17.5 CONTRACTOR shall submit a specific traffic control plan for temporary traffic routing and signage during construction. Traffic control plan shall comply with rules and regulations of the City and state authorities regarding closing or restricting the use of public streets or highways. No public or private road shall be closed, except by written permission of the proper authority. CONTRACTOR shall assure the least possible obstruction to traffic and normal commercial pursuits.

CONTRACTOR shall notify the Department of Public Works, and Department of Public Safety before closing any street or portion thereof and notify said departments when the streets are again possible for emergency vehicles. Do not block off emergency vehicle access without written permission from the Unalaska Fire Department. CONTRACTOR shall conduct operations with the least interference to fire equipment access, and at no time prevent such access.

CONTRACTOR shall leave a night emergency telephone number or numbers with the Police Department, so that contact may be made easily at all times in case of barricade and flare trouble or other emergencies.

- 6.17.6 The CONTRACTOR shall provide a site specific Safety Plan which shall include but not be limited to regulations outlined within the Code of Federal Regulations 29 CFR within Part 1910 Occupational Safety and Health Administration (OSHA) standard number 1910.120 Hazardous Waste Operations and Emergency Response (HAZWOPER) training. The Safety Plan will include all applicable parts of these regulations.

- 6.22.1 The CONTRACTOR shall assume the responsibility for protection of finished construction and shall repair and restore any and all damage to finished work to its original condition.

In unfinished areas, CONTRACTOR shall leave the site evenly graded as necessary, in a condition that will restore original drainage, and with an appearance equal to or better than original.

6.22.2 Any monument damaged or displaced by the Contractor shall be replaced in accordance with the Title 8 of the City of Unalaska Code of Ordinances. The cost of replacing or repairing damaged or displaced monuments shall be borne solely by the Contactor.

6.27 Meetings

The CONTRACTOR and all subcontractors currently working shall attend all weekly construction progress meetings held at the City Department of Public Works. CONTRACTOR shall provide construction progress update, weekly project schedule updates, construction issues, coordination with City, etc.

SC-11 ARTICLE 5 – BONDS, INSURANCE, AND INDEMNIFICATION

5.4 Insurance Requirements:

Remove paragraph 5.4.3.10. Builder's Risk Insurance is not required for the project.

-END OF SUPPLEMENTARY CONDITIONS-

Part 4

STATE OF ALASKA Minimum Rates of Pay

Pamphlet 600 – Issue 27
Effective September 1, 2013

Available online at:

<http://labor.state.ak.us/lss/forms/pamp600-090113.pdf>

Part 5

DRAWINGS

CITY OF UNALASKA PORT LIGHTING UPGRADES

Drawing List

Project Design Drawings:

SHEET No.	REV No.	TITLE
1	0	COVER SHEET
2	0	SITE PLAN – UMC CITY DOCK
3	0	SITE PLAN – UMC USCG DOCK
4	0	SITE PLAN – LIGHT CARGO DOCK
5	0	SITE PLAN – SPIT DOCK
6	0	HIGH MAST LIGHT DETAILS
7	0	GENERAL NOTES
E1	0	ELECTRICAL LEGEND AND FIXTURE SCHEDULE
E2	0	ELECTRICAL DEMOLITION – UMC CITY DOCK
E3	0	ELECTRICAL DEMOLITION – UMC USCG DOCK
E4	0	ELECTRICAL DEMOLITION – LIGHT CARGO DOCK
E5	0	ELECTRICAL DEMOLITION – SPIT DOCK
E6	0	LIGHTING REMODEL PLAN – UMC CITY DOCK
E7	0	LUMINAIRE AIMING PLAN – UMC CITY DOCK
E8	0	LIGHTING REMODEL PLAN – UMC USCG DOCK
E9	0	LUMINAIRE AIMING PLAN – UMC USCG DOCK
E10	0	LIGHTING REMODEL PLAN – LIGHT CARGO DOCK
E11	0	LUMINAIRE AIMING PLAN – LIGHT CARGO DOCK
E12	0	LIGHTING REMODEL PLAN – SPIT DOCK
E13	0	ELECTRICAL DETAILS
E14	0	ELECTRICAL SPECIFICATIONS
E15	0	ELECTRICAL SPECIFICATIONS

Part 6
SITE PHOTOS



PHOTO 1. Ballyhoo Road along the UMC City Dock Backreach Area (looking NE).



PHOTO 2. HMLs at UMC City Dock.



PHOTO 3. Base of South HML at UMC City Dock.



PHOTO 4. Base of North HML at UMC City Dock.



PHOTO 5. Ballyhoo Road along the UMC City Dock Backreach Area (looking SW).



PHOTO 6. Base of South HML at UMC USCG Dock.



PHOTO 7. Base of North HML at UMC USCG Dock (looking NE).



PHOTO 8. Base of North HML at UMC USCG Dock (looking N).



PHOTO 9. Ballyhoo Road (along the Spit) near the Light Cargo Dock (looking SW).



PHOTO 10. Light Pole at Light Cargo Dock.



PHOTO 11. Base of North HML at Light Cargo Dock.



PHOTO 12. Base of South HML at Light Cargo Dock.



PHOTO 13. Light Pole on Approach at Spit Dock.



PHOTO 14. Light Pole on Floating Dock at Spit Dock.

Part 7

**LIGHT CARGO DOCK
EXISTING HIGH MAST LIGHT INFORMATION**

Submittal Information



CAROLINA HIGH MAST, INC.

CHM: Lic. Manufacturer Of G.E. Lowering Device Design

P.O. Box 14069
Haltom City, TX 76117
(817) 834-3500
FAX (817) 834-9700

SUBMITTAL

PROJECT NAME: UNALASKA CARGO DOCK, AK.

EQUIPMENT: QTY (2) C522G627
MSSP-TL-ED-120-G-120-N-12-F-2-C-WCS4-WS-NC2-FAA-120
120' GALV. STEEL POLE WITH ANCHOR BOLTS.
TOP LATCH EXTERNAL DRIVE LOWERING DEVICE W/SPRING
ARM SYSTEM FOR 12 FLOODLIGHT FIXTURES, 1/4" STAINLESS
STEEL WINCH CABLE, WINCH CABLE GUARDS, 2 CIRCUITS,
SINGLE OBSTRUCTION AIRCRAFT WARNING LIGHT.
120 MPH X 1.3 GUST
* ELECTRICAL IS SINGLE PHASE, 3-WIRE, 208V
* CIRCUIT #1- 12 FIXTURES
* CIRCUIT #2- OBSTRUCTION LIGHT 120V (DEDICATED CIRCUIT)

QTY (1) C408G627
PORTABLE POWER UNIT WITH STEPDOWN TRANSFORMER.

QTY (2) PC-01
PILE CAP ASSEMBLY TO MATCH BASE.

JOB NUMBER: 00-627

DATE: JANUARY 26, 2000

SPECIAL PROVISIONS FOR UNALASKA CARGO DOCK, AK.:

- | | | |
|-----|--|--|
| 1) | NUMBER OF LUMINAIRE MOUNTING TENONS..... | 3 |
| 2) | DEGREE OF SPACING TENONS..... | 120 |
| 3) | LENGTH OF TENON..... | (1)-33"X12" T-TENON, (2)-60" STRAIGHT |
| 4) | POWER CABLE..... | 5 COND, 6 AWG, TYPE SEO |
| 5) | POWER CONNECTORS..... | 2P, 3W, 80A, 240V
HUBBLE TWIST-LOCK OR EQUIV |
| 6) | LUMINAIRE WIRING..... | 3 COND, 16 AWG, TYPE SEO |
| 7) | TERMINAL BOX..... | CAST ALUMINUM |
| 8) | LOWERING DEVICE..... | TOP LATCH / SPRING ARM |
| 9) | LIGHTNING PROTECTION..... | BY CONTRACTOR |
| 10) | TERMINAL BLOCK..... | PREWIRED 600 VOLT AC |
| 11) | CIRCUIT BREAKER..... | CIRCUIT #1- QTY (1) 2P, 80A, 208V
CIRCUIT #2- QTY (1) 2P, 15A, 208V |
| 12) | ELECTRICAL SERVICE..... | CIRCUIT #1 1 PHASE, 2W, 208V PLUS GROUND
CIRCUIT #2 1 PHASE, 2W, 208V PLUS GROUND |
| 13) | FIXTURE PRIMARY..... | 208V |

TOP LATCHING SPECIFICATION (MODEL C522G627)
UNALASKA CARGO DOCK, AK.

HEADFRAME ASSEMBLY

The headframe assembly shall consist of a 1/4" (6.350 mm) thick minimum top plate, with sheave support plates fabricated from a minimum 11 gauge steel sheet. The sheave support plate shall be welded to the headframe base plate. All steel plates shall be laser cut for accuracy. The complete headframe assembly shall be hot dipped galvanized per ASTM A-123 after fabrication.

Hoist cables shall operated over corrosion resistant 5-inch (127 mm) diameter aluminum steel sheaves. The entire cable groove surface shall be machined to eliminate any rough surface on which the cable shall ride.

The main power cord shall be supported by a minimum of two large 6-inch (152.4 mm) non-conductive thermoplastic polymer cord sheaves grooved to provide for a non-abrasive smooth operation. A two piece threaded male and female thermoplastic polymer insulating bushing assembly shall be installed on the headframe opening to prevent wear on the power cord as it travels up and down the pole.

All sheaves shall have sintered bronze oilite bearings and run on a stainless steel axle secured with self-locking stainless steel hardware. Keeper bars shall be positioned at both ends of the sheave assemblies to keep the cord in its track during pole erection and during normal operation.

The top latching assembly shall contain three (3) symmetrically located, extremely stout, precision cast matching stainless steel latch pin and enclosed cam mechanism to assure corrosion resistant, trouble-free operation for years to come. All moving latch parts are bolted to the ring for servicing from the ground. The complete two part latch pin and cam assembly shall be made of stainless steel (type 316) material. There shall be no moving latch parts or springs attached to the headframe assembly. All motion required to achieve latching or unlatching shall be internal to the latch cam, this will help prevent shock and vibration damage to the lamps and luminaries, as well as preventing the formation of ice build-up on the latching mechanism.

Latching occurs by the alternate raising and lowering of the luminaire ring. When latching of the ring occurs no horizontal movement of the fixtures which can cause fixture damage is permitted.

When in the latch position the space between the headframe and the luminaire ring shall be no more than six inches when in the latched position. The use of "Z" type top latching system is not an acceptable alternate to the stainless steel latch cam.

All hardware is corrosion resistant stainless steel.

The headframe assembly shall have a copper-free, spun aluminum cover, retained on its 360 degree perimeter by a stainless steel clamp band with stainless steel safety latching pin with

self-locking hardware. The dome and clamp band assembly shall provide an air-tight seal against the elements for the headframes roller assemblies.

The headframe cover shall bolt directly to the high mast pole. The headframe base plate and pole top plate shall have four 9/16" (5 mm) by 3" (76.2 mm) slotted holes to accommodate 1/2" (12.7mm) type 18-8 stainless steel hardware.

THE LUMINAIRE RING ASSEMBLY

The luminaire ring shall be fabricated to 6" (152 mm) x 2" (50.8 mm) x #7 gauge spun steel per ASTM A-569, with the appropriate number of luminaire mounting tenons, hot dipped galvanized per ASTM A-123 after fabrication. The luminaire ring shall have a prewired, weathertight, corrosion resistant aluminum enclosure with 3 conductor, 16 AWG., type SEO 105 degree cable. The prewired distribution box shall be capable of accepting up to 16 fixtures, with 600 volt terminal blocks for each individual fixture wire. A weathertight twist lock test inlet shall be mounted to the terminal box to permit testing of the luminaires while the ring is in the lowered position. A single obstruction light will mount to a 5' piece of conduit and get bolted directly to one of the 2 1/2" square tenons by way of a special mounting bracket. (CHM to provide)

The luminaire ring shall contain a quantity of three, roller-contact, spring-loaded stainless steel centering arms with polymer rollers to center the ring and prevent shock to the lamps from impact of ring with the pole.

Highly visible 6" (152 mm) minimum retroreflective position indicator flags make for easy day or night operation.

The three hoist cables shall be stainless steel aircraft cord, 3/16" (4.762 mm) diameter manufactured to meet MIL-W83420C. Winch cable will be stainless steel 1/4" (6.350 mm) diameter cable, manufactured to meet MIL-W83420C. These special cables are specifically designed for lowering device applications and virtually make "twistings" a thing of the past. Swivel bearings may be used in the transition assembly but they shall not take the place of the anti-rotational cable.

A transition assembly shall be supplied to attach the winch cable to the three hoist cables and the main power cord.

The three hoist cables shall pass up through the pole shaft, over the headframe hoist cable sheaves, to the luminaire ring, where they travel through the stainless steel latch pin and stainless steel guides and compression spring assembly and terminate with a collet-type strand-vise device.

THE WINCH PLATE ASSEMBLY

Two Square "D" circuit breakers shall be mounted in an aluminum enclosure on the winch sub-plate to act as the disconnecting means for the lowering device. One breaker will be dedicated

for the single obstruction light while the other breaker will control the (12) fixtures on the ring. Prewired to the breaker shall be a twist-lock, weathertight connector matching those used in the system, mounted to a 8' (2.5M) tail of power cord of the same type, gauge and number of conductors as the power cord. This cord and connector shall be used to alternately supply power to the lowering device system, the test inlet and the mobile cart system. In addition, cable guards will be mounted on the winch plate to maintain the 1/4 winch cable on the on the drum.

THE PORTABLE POWER UNIT ASSEMBLY (C508G627)

The portable power unit shall incorporate the heavy-duty reversing type drive motor, torque limiter, drive shaft and electrical controls. The Torque limiter is factory set to provide safe reliable operation. Twenty-five foot (8M) long cord on the remote electrical control box provides for remote operation of the portable power unit. The drive motor is a heavy duty 120 volt reversing electrical drill.

The portable power unit shall be provided with a weatherproof, portable enclosed stepdown transformer to operate the 120 volt power unit.

COVER
(aluminum)
HEADFRAME
(hot dipped galvanized)

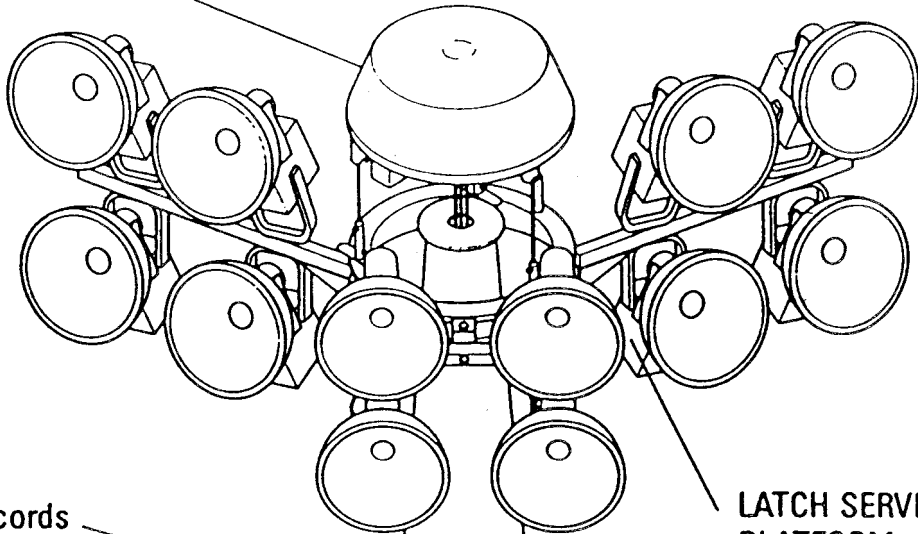

LATCH SERVICE
PLATFORM

main power cords
3 lift cords

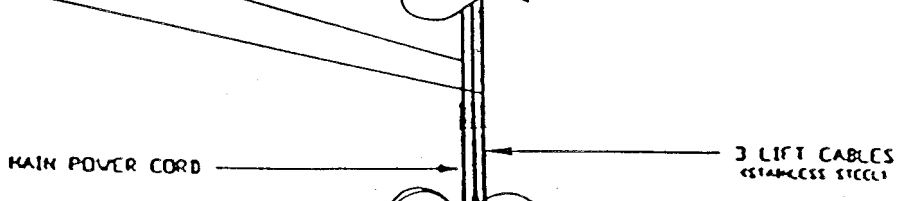

MAIN POWER CORD

3 LIFT CABLES
(STAINLESS STEEL)

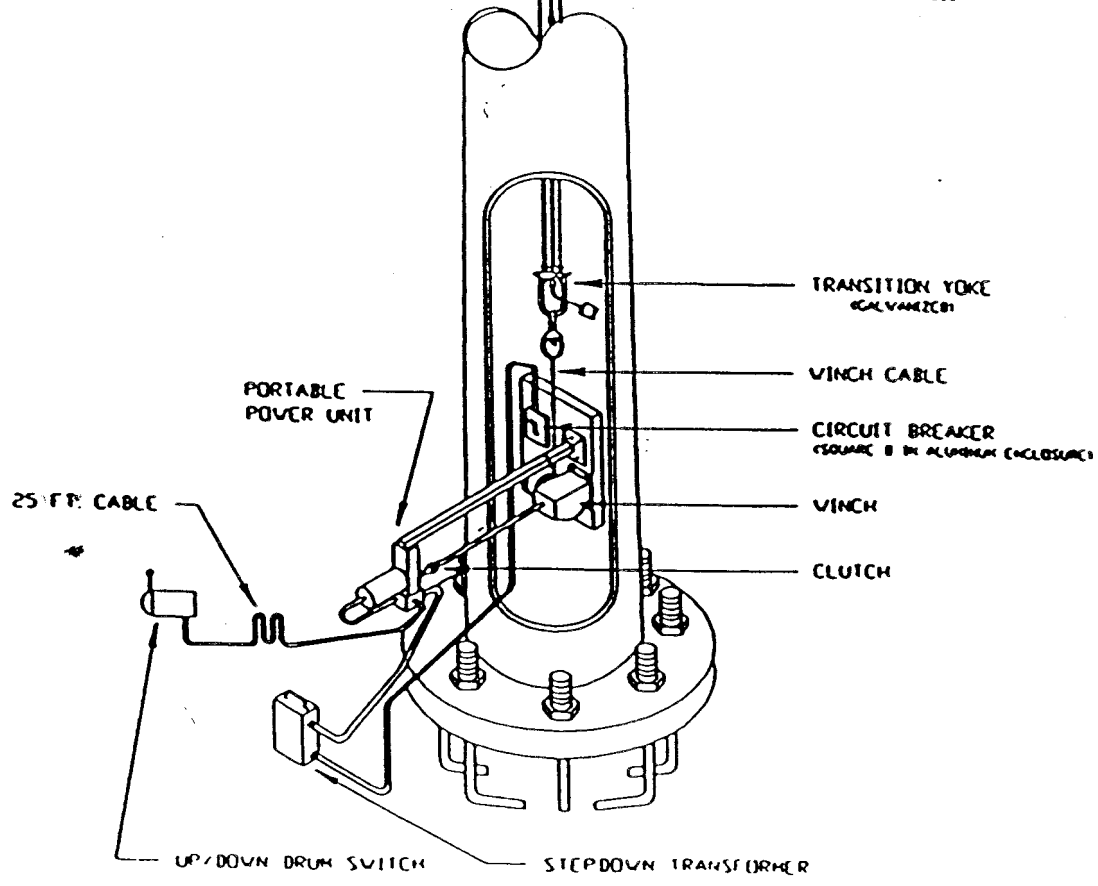

TRANSITION YOKE
(GALVANIZED)

WINCH CABLE

CIRCUIT BREAKER
(SQUARE D IN ALUMINUM ENCLOSURE)

WINCH

CLUTCH

PORTABLE
POWER UNIT

25 FT. CABLE

UP/DOWN DRUM SWITCH

STEPDOWN TRANSFORMER

COVER AND CLAMP BAND, LATCHING
Reference Print 35-232532

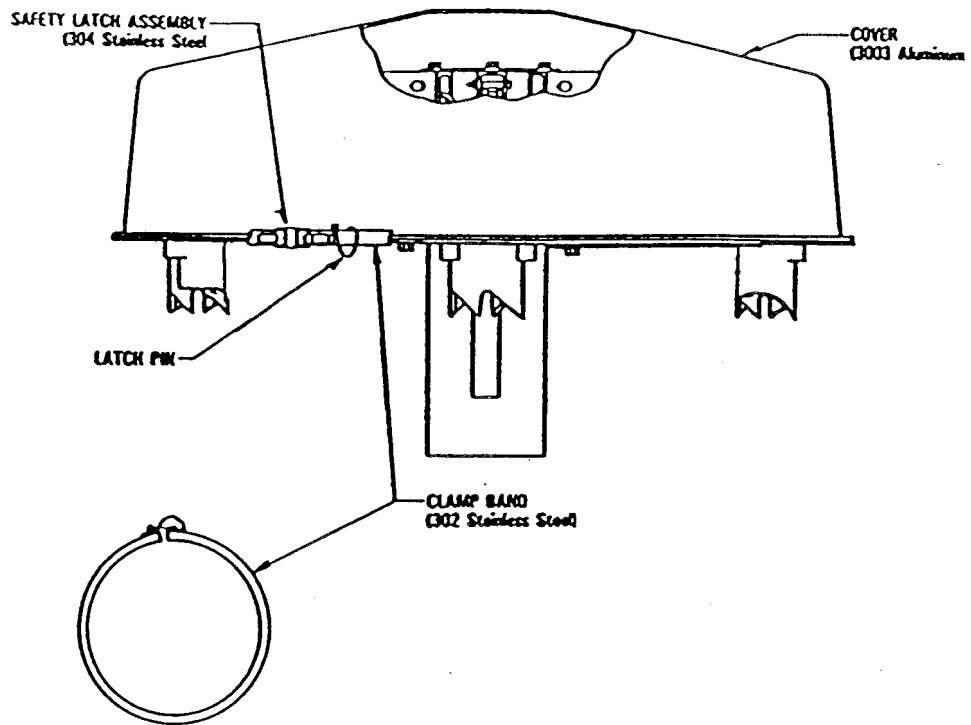

TOP ASSEMBLY, LATCHING
Reference Print 35-232533

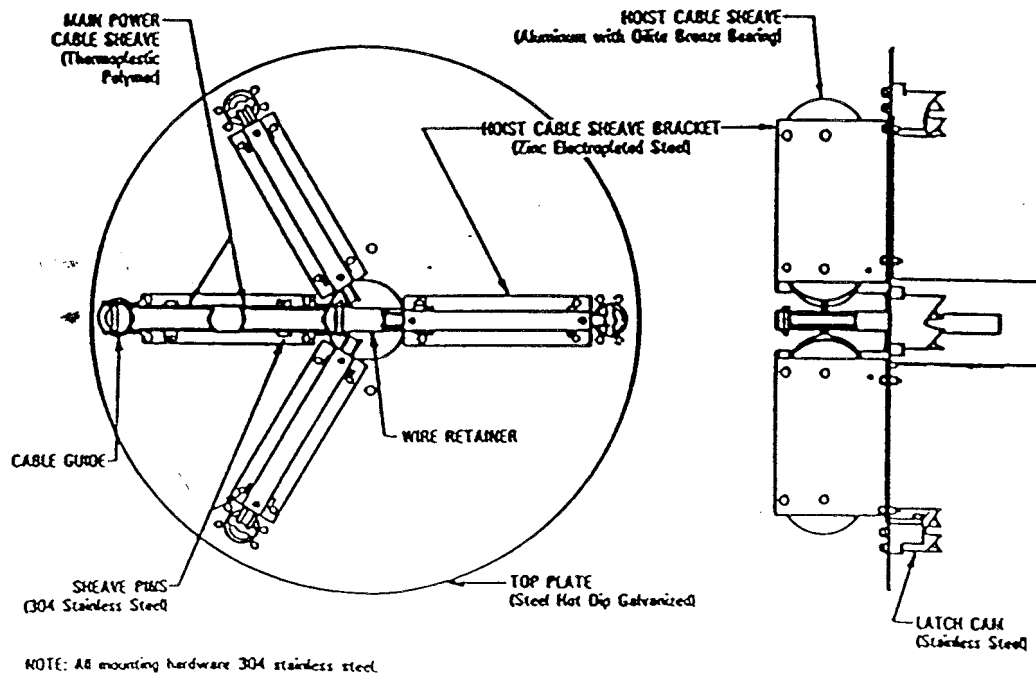

HEAD FRAME AND SUPPORT RING ASSEMBLY, LATCHING
Reference Print 35-310132

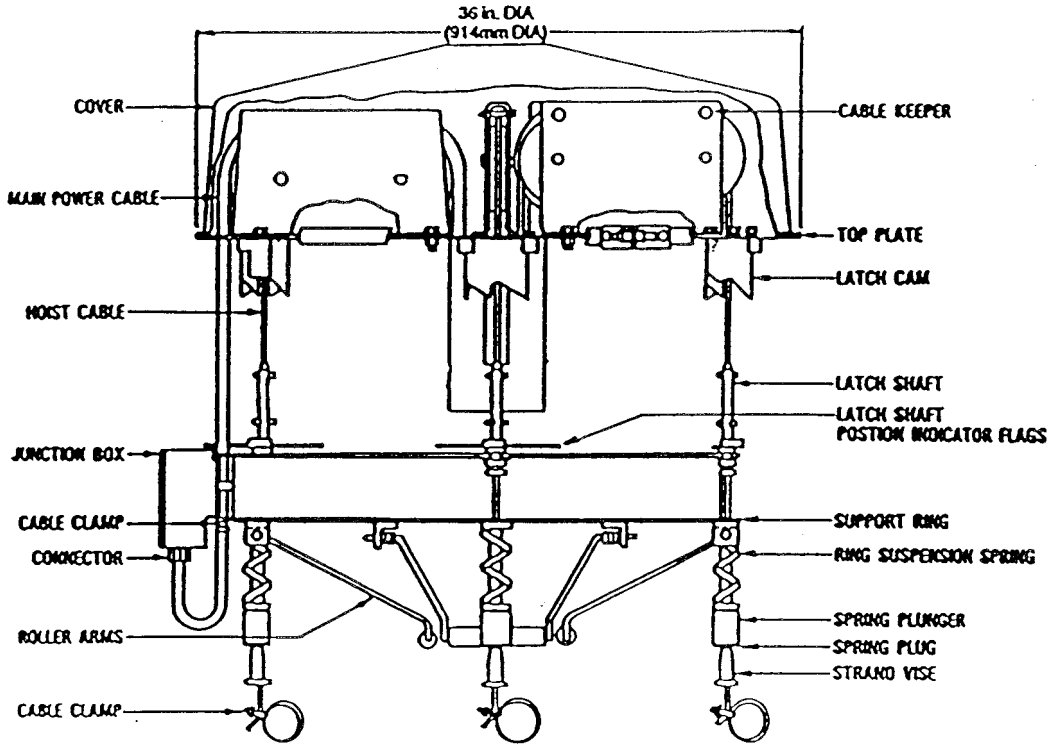

JUNCTION-BOX AND RING
Reference Print 35-311638

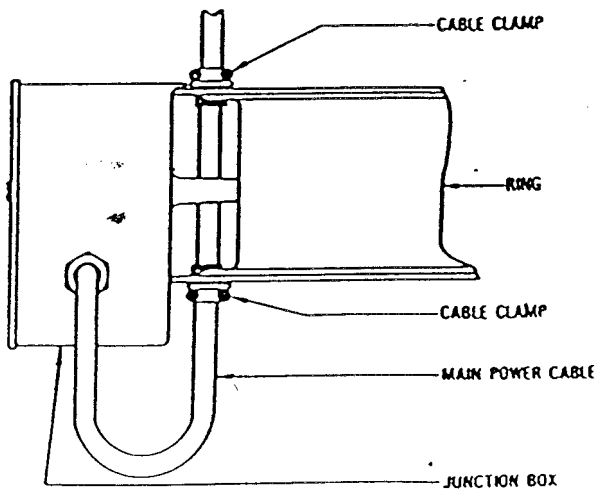

Carolina High Mast
Haltom City, Tx. 76117
Ph. # 817-834-3500

Pole Plate Assembly

Representative Pole Plate Assembly
with Circuit Breaker
Reference 35 222626

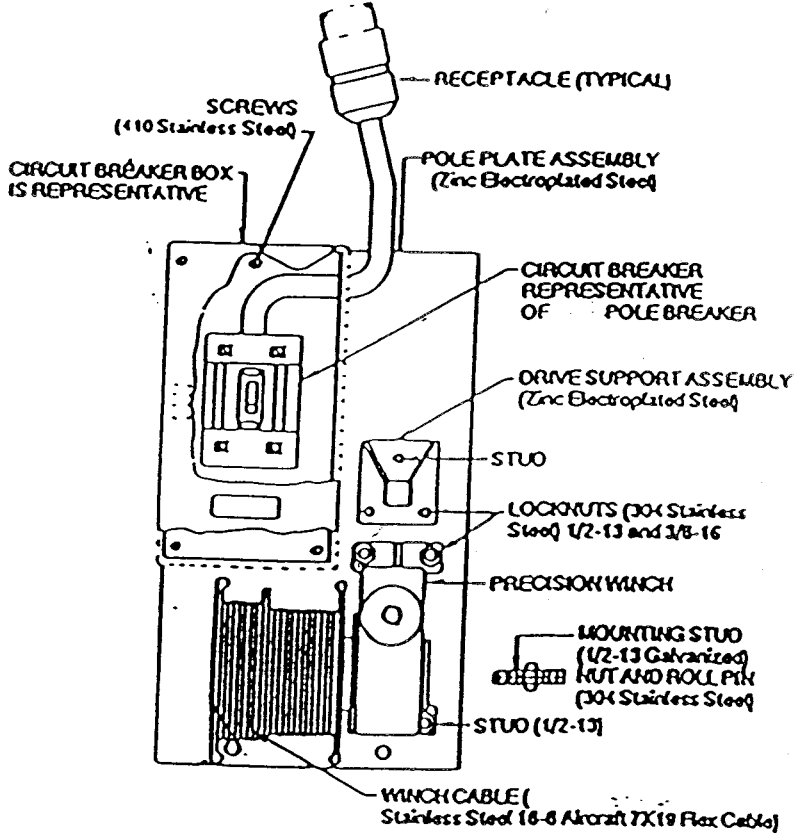

Carolina High Mast
Haltom City, Tx. 76117
Ph. # 817-834-3500

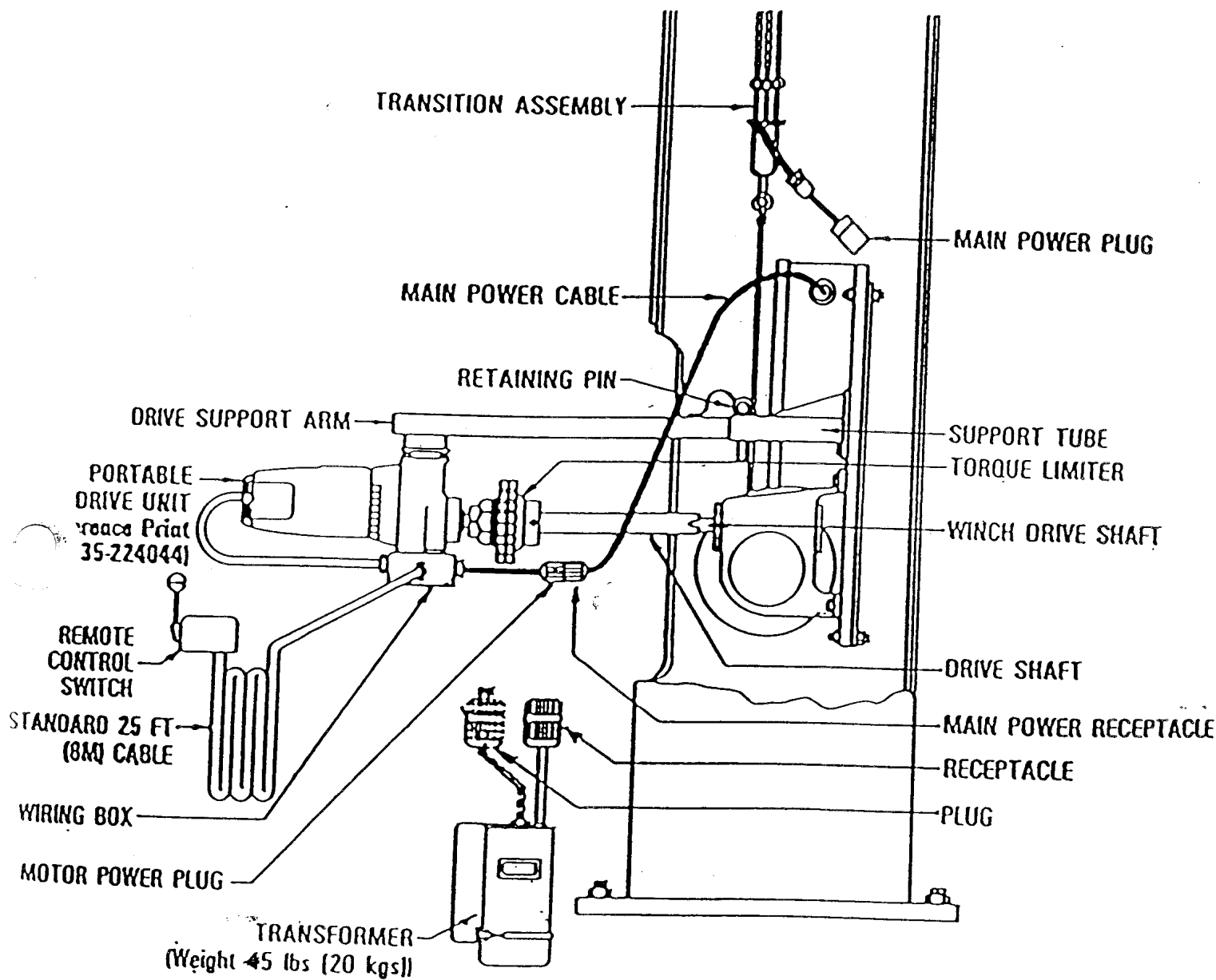

SPORTSTAR™ CONFIGURATIONS

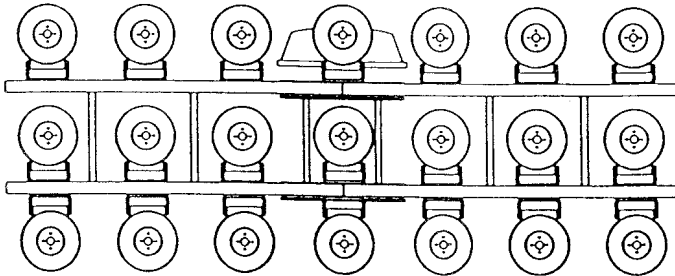

19 to 21 floodlights (typical) — 3 rows of 7 fixtures each

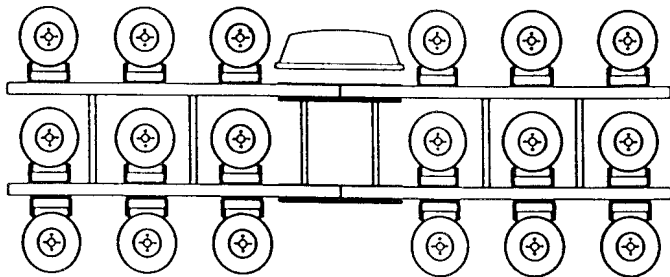

16 to 18 floodlights (typical) — 3 rows of 6 fixtures each

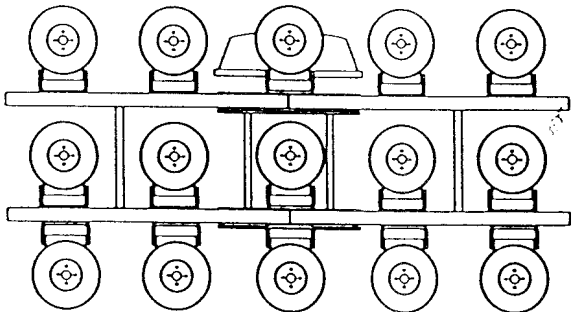

13 to 15 floodlights (typical) — 3 rows of 5 fixtures each

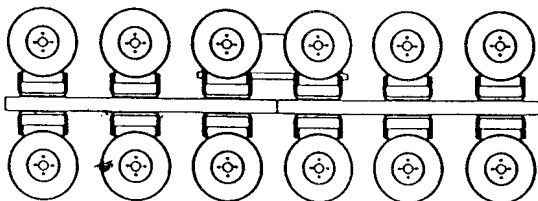

11 to 12 floodlights (typical) — 2 rows of 6 fixtures each

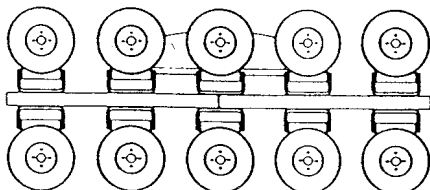

10 floodlights (typical) — 2 rows of 5 fixtures each

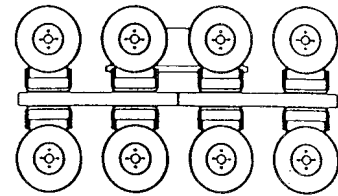

8 floodlights (typical)
2 rows of 4 fixtures each

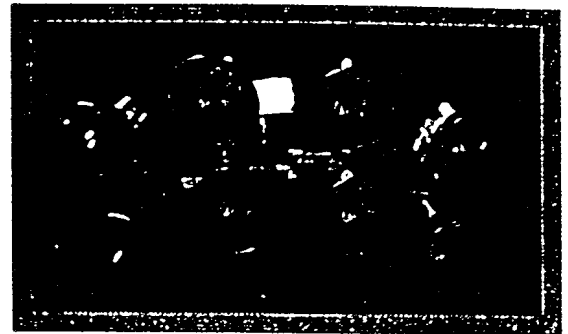

This photo demonstrates the lighting configuration for 8 GE Powr-Spot® floodlights

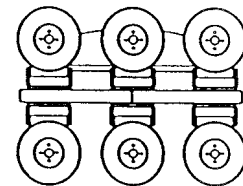

6 floodlights (typical)
2 rows of 3 fixtures each

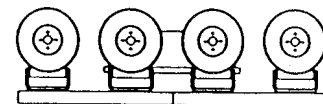

4 floodlights (typical)

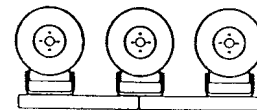

3 floodlights (typical)



2 floodlights (typical)

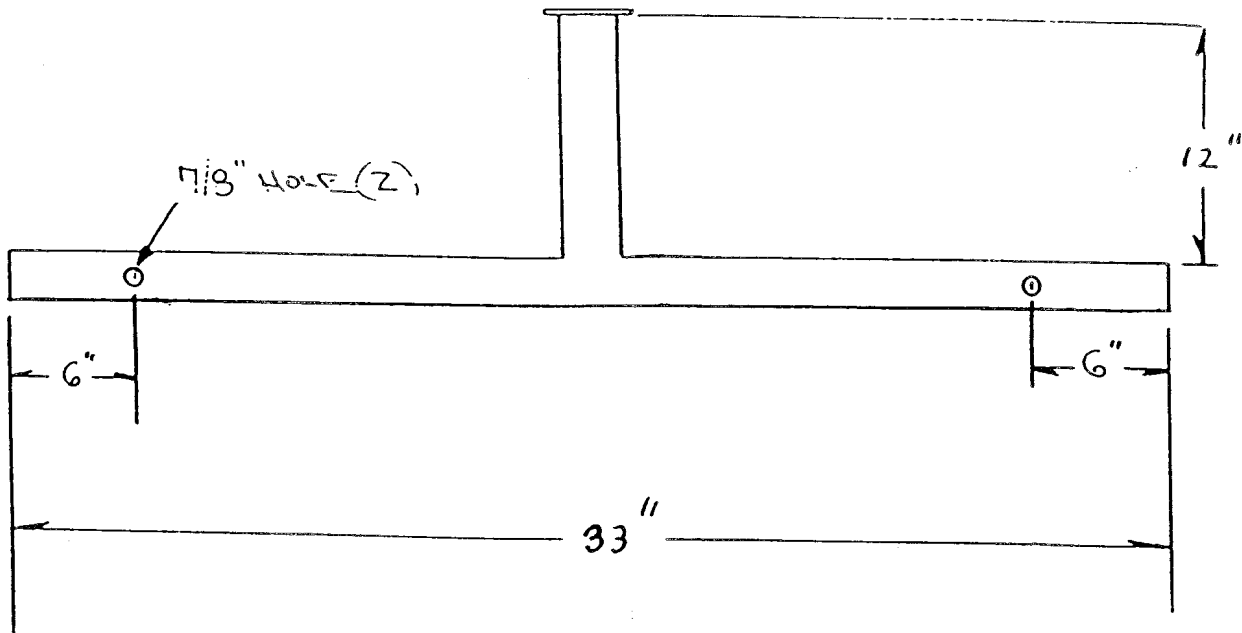

CAROLINA HIGH MAST, INC.

THIS INFORMATION IS THE PROPERTY OF CAROLINA HIGH MAST, INC. AND SHALL NOT BE REPRODUCED IN WHOLE OR IN PART, USED IN ANY MANNER, OR DELIVERED TO ANYONE WITHOUT THE EXPRESS WRITTEN CONSENT OF CAROLINA HIGH MAST, INC. THE INFORMATION CONTAINED WITHIN ANY ASSOCIATION DOCUMENTATION IS AND SHALL REMAIN OWNED BY CAROLINA HIGH MAST, INC.

SCALE:

APPROVED BY:

DRAWN BY

DATE:

REVISED

33" X 12" T-TENON

DRAWING NUMBER

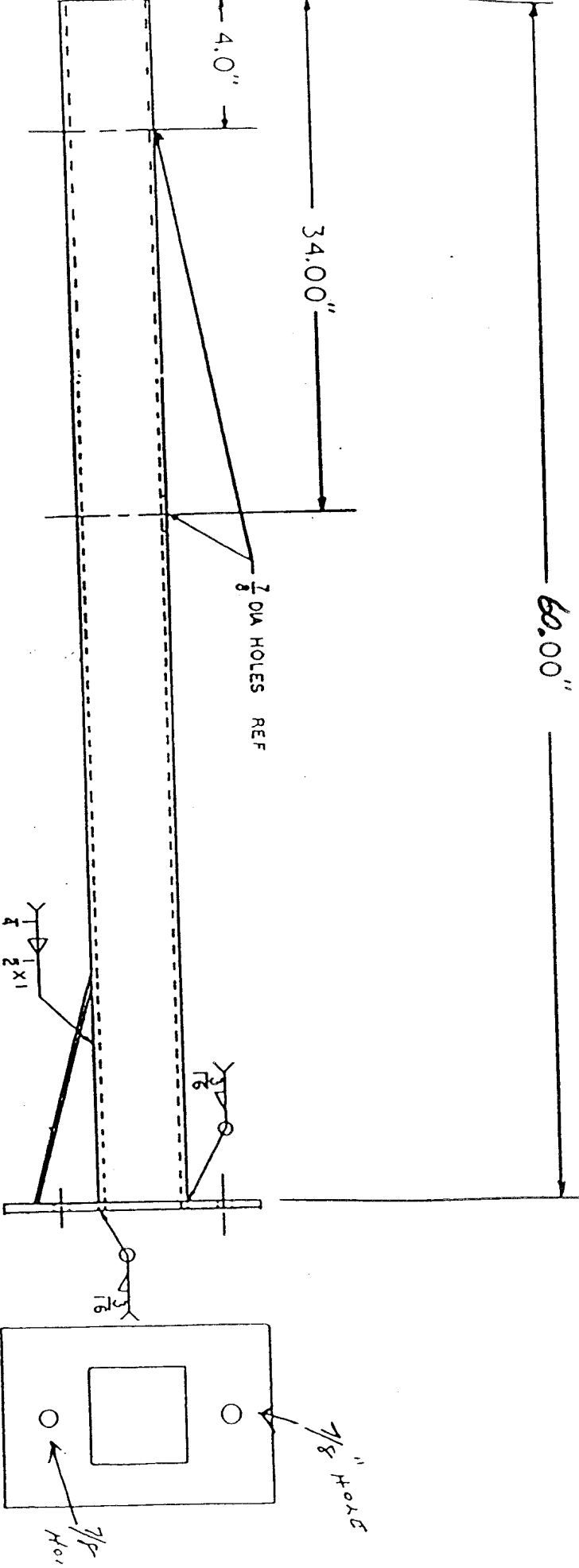

02 FINISH ASTM A123

TOLERANCES (EXCEPT AS NOTED)		REVISIONS			CAROLINA HIGH MAST		
DECIMAL	FRACTIONAL	NO	DATE	BY	DESCRIPTION	DATE	MATERIAL
		1			TENON SQUARE 60°		
		2					
		3					
		4					
		5					

DATE	BY	DATE	BY
11/27/97	DAVID		

PART NO.	REVISION	LAST GROUP NO.	LAST FIG. NO.
----------	----------	----------------	---------------

PART NO.	REV.
----------	------

J-BOX ON RING

EACH LUMINAIRE WIRED TO TERMINAL BLOCK WITH SEPARATE
#16-3 ST 105°C CORD LUMINAIRES WIRED 208V.

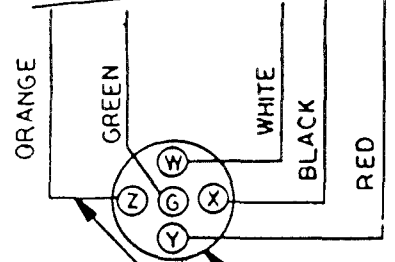
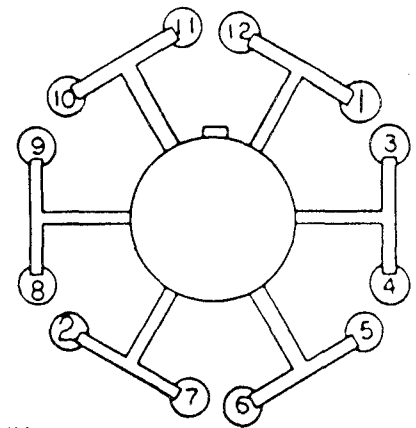
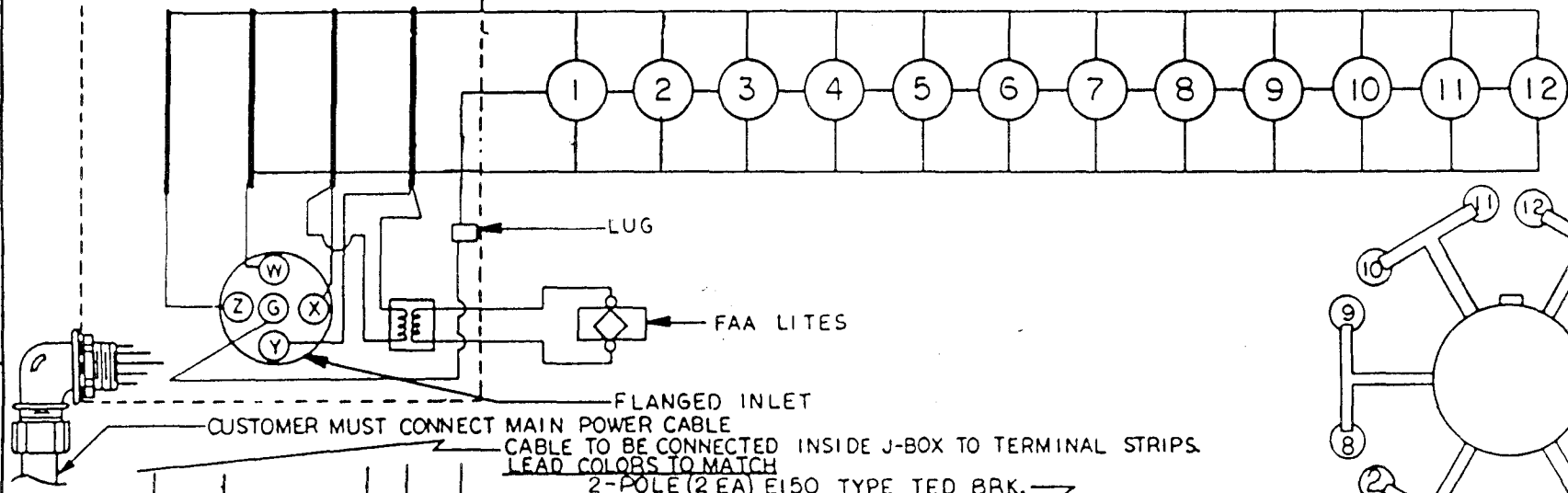

PIG TAIL PREWIRED

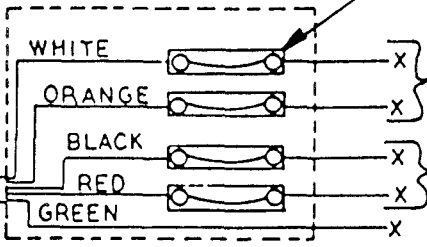
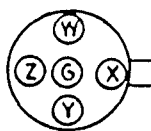

MAIN CIR. 12 LUM CUSTOMER LINE
OBSTRUCTION LIGHT CIRCUIT
EQ. GROUND

5-COND CORD
600V

PLUG
PREWIRED BY FACTORY

REV. NO.	REVISION BY	DATE	FIG. NO.
2	WARD	4-27-87	8251-89
1	CANNON	7-3-86	562-86

TOLERANCES UNLESS OTHERWISE SPECIFIED		
FRACTIONS	DECIMALS	ANGLES
1/16	0.001	1/2
GENERAL ELECTRIC		
LIGHTING SYSTEMS DEPARTMENT HINDSBOROUGH, N.H. 03040		

PL. NO.	DESCRIPTION	MATERIAL
DR. BY: CANNON	DATE: 7-12-85	
APPROVED:	DATE: 7-15-85	BOX: 467-85
TITLE: CUSTOMER WIRING		
DRAWING NO. 35-310596	SHEET 1	CONT. ON

35-310596

PRINT MACHINE INC.

Carolina Highmast
PO Box 14069
Haltom City, TX 76117
(817) 834-3500
(817) 834-9700 fax

Thursday, January 27, 2000 21:12:09

Unalaska Cargo Dock
120' pole with 12 fixtures

Page 1

Carolina Highmast
 PO Box 14069
 Haltom City, TX 76117
 (817) 834-3500
 (817) 834-9700 fax

Pole Description

Specification: Whitco Standard

Wind Speed: 120 Mph Isotach
 156 Mph Gust Velocity

3 Section Pole:

Sect No	Bottom	Top	Length (Ft)	Thick (In)	Yield Strength (Psi)	Weight (Lb)	Sides	Inside
	O.D. (In)	O.D. (In)						B.R. (In)
1	27.75	20.97	48.44	0.25000	65000.	3263.	16	4.00
2	22.00	15.69	45.09	0.25000	65000.	2342.	16	4.00
3	16.50	11.82	33.39	0.18750	65000.	988.	16	4.00

Pole Total Weight: 6593. Lb
 Pole Total Length: 120.00 Ft
 Pole Steps: No
 Base Elevation: 0.00 Ft

2 Joints:

Joint No	Joint Type	Length (In)	Joint Description
1	Standard Slip	45.62	
2	Standard Slip	37.56	

3 Loads:

Load No	Attach Elev (Ft)	Z Cent (Ft)	X Cent (Ft)	Y Cent (Ft)	Fixture or Symmetry	E.P.A. (Sq m)	Weight (Lb)
1	120.00	120.00	0.00	0.00		16.20	300.
2	119.00	119.00	0.00	0.00		4.10	325.
3	118.00	118.00	0.00	0.00		16.20	300.

Unalaska Cargo Dock
 120' pole with 12 fixtures

Carolina Highmast
 PO Box 14069
 Haltom City, TX 76117
 (817) 834-3500
 (817) 834-9700 fax

Section Properties

Elev Ft	Roundness Ratio %	Pole Diam In	Pole Sides	Pole Thick In	Section Modulus In ³	MomentOf Inertia In ⁴	CrossSect Area In ²
0.00	98.66	27.750	16	0.2500	148.148	2095.830	21.880
5.00	98.67	27.050	16	0.2500	140.670	1939.833	21.323
10.00	98.69	26.350	16	0.2500	133.385	1791.775	20.766
14.00	98.70	25.790	16	0.2500	127.697	1678.906	20.321
15.00	98.71	25.650	16	0.2500	126.294	1651.450	20.209
20.00	98.72	24.950	16	0.2500	119.396	1518.649	19.653
25.00	98.74	24.250	16	0.2500	112.693	1393.166	19.096
29.00	98.76	23.690	16	0.2500	107.469	1297.909	18.650
30.00	98.76	23.550	16	0.2500	106.182	1274.794	18.539
35.00	98.78	22.850	16	0.2500	99.866	1163.324	17.982
40.00	98.81	22.150	16	0.2500	93.744	1058.549	17.425
44.64	98.83	21.500	16	0.2500	88.232	967.073	16.908
45.00	98.83	21.450	16	0.2500	87.815	960.263	16.868
48.44	98.83	21.468	16	0.2500	87.963	962.677	16.882
49.00	98.83	21.390	16	0.2500	87.315	952.133	16.820
50.00	98.84	21.250	16	0.2500	86.156	933.344	16.709
55.00	98.86	20.550	16	0.2500	80.476	843.094	16.152
60.00	98.89	19.850	16	0.2500	74.990	758.859	15.595
65.00	98.92	19.150	16	0.2500	69.698	680.430	15.038
70.00	98.95	18.450	16	0.2500	64.599	607.601	14.481
75.00	98.99	17.750	16	0.2500	59.694	540.163	13.924
80.00	99.03	17.050	16	0.2500	54.983	477.910	13.367
85.00	99.07	16.350	16	0.2500	50.465	420.634	12.810
86.61	99.08	16.125	16	0.2500	49.054	403.247	12.631
89.74	99.07	16.062	16	0.1875	36.926	302.363	9.473
90.00	99.07	16.025	16	0.1875	36.754	300.265	9.451
95.00	99.12	15.325	16	0.1875	33.560	262.188	9.033
100.00	99.17	14.625	16	0.1875	30.510	227.474	8.615
105.00	99.23	13.925	16	0.1875	27.606	195.969	8.198
110.00	99.29	13.225	16	0.1875	24.846	167.516	7.780
115.00	99.36	12.525	16	0.1875	22.233	141.960	7.362
118.00	99.40	12.105	16	0.1875	20.734	127.952	7.112
119.00	99.42	11.965	16	0.1875	20.246	123.496	7.028
120.00	99.43	11.825	16	0.1875	19.764	119.145	6.945

Unalaska Cargo Dock
 120' pole with 12 fixtures

Carolina Highmast
 PO Box 14069
 Haltom City, TX 76117
 (817) 834-3500
 (817) 834-9700 fax

Wind - Weight Loads

Elev Range Ft	Z Cent Ft	X Cent Ft	Y Cent Ft	Weight Force Lb	Proj Area Ft^2	Drag Coeff	Wind Press Psf	Wind Force Lb
0.00 - 5.00	2.49	0.00	0.00	379.23	11.5709	0.53	49.84	307.57
5.00 - 10.00	7.49	0.00	0.00	369.46	11.2736	0.53	49.84	297.49
10.00 - 14.00	11.99	0.00	0.00	288.52	8.8047	0.53	49.84	230.73
14.00 - 15.00	14.50	0.00	0.00	71.15	2.1714	0.52	50.67	57.62
15.00 - 20.00	17.49	0.00	0.00	349.90	10.6788	0.52	54.82	305.05
20.00 - 25.00	22.49	0.00	0.00	340.12	10.3814	0.52	58.98	316.23
25.00 - 29.00	26.99	0.00	0.00	265.06	8.0910	0.51	62.30	258.16
29.00 - 30.00	29.50	0.00	0.00	65.29	1.9930	0.51	62.61	63.60
30.00 - 35.00	32.49	0.00	0.00	320.57	9.7867	0.51	64.17	318.10
35.00 - 40.00	37.49	0.00	0.00	310.79	9.4893	0.50	65.73	312.52
40.00 - 44.64	42.31	0.00	0.00	279.84	8.5452	0.50	67.17	284.42
44.64 - 45.00	44.82	0.00	0.00	42.19	0.6616	0.49	67.28	21.63
45.00 - 48.44	46.72	0.00	0.00	392.41	6.1567	0.48	68.36	201.51
48.44 - 49.00	48.72	0.00	0.00	32.86	1.0034	0.49	68.53	33.84
49.00 - 50.00	49.50	0.00	0.00	58.86	1.7976	0.49	68.72	60.66
50.00 - 55.00	52.49	0.00	0.00	288.44	8.8096	0.49	69.65	298.97
55.00 - 60.00	57.49	0.00	0.00	278.66	8.5122	0.48	70.59	288.70
60.00 - 65.00	62.49	0.00	0.00	268.89	8.2148	0.47	71.52	278.06
65.00 - 70.00	67.48	0.00	0.00	259.11	7.9174	0.47	72.46	267.03
70.00 - 75.00	72.48	0.00	0.00	249.33	7.6200	0.46	73.39	255.62
75.00 - 80.00	77.48	0.00	0.00	239.55	7.3227	0.45	74.32	244.91
80.00 - 85.00	82.48	0.00	0.00	229.77	7.0253	0.45	75.26	237.92
85.00 - 86.61	85.80	0.00	0.00	71.78	2.1950	0.45	75.56	74.63
86.61 - 89.74	88.17	0.00	0.00	239.22	4.2843	0.45	76.14	146.80
89.74 - 90.00	89.87	0.00	0.00	8.83	0.3548	0.45	76.19	12.17
90.00 - 95.00	92.48	0.00	0.00	163.92	6.5908	0.45	77.13	228.75
95.00 - 100.00	97.48	0.00	0.00	156.51	6.2935	0.45	78.06	221.08
100.00 - 105.00	102.48	0.00	0.00	149.10	5.9961	0.45	79.00	213.15
105.00 - 110.00	107.48	0.00	0.00	141.69	5.6987	0.45	79.93	204.98
110.00 - 115.00	112.48	0.00	0.00	134.28	5.4013	0.45	80.87	196.55
115.00 - 118.00	116.49	0.00	0.00	77.01	3.0980	0.45	81.43	113.52
118.00 - 119.00	118.50	0.00	0.00	25.08	1.0089	0.45	81.61	37.05
119.00 - 120.00	119.50	0.00	0.00	24.78	0.9970	0.45	81.80	36.70
Load 1	120.00	0.00	0.00	300.00	16.2000	1.00	81.80	1325.16
Load 2	119.00	0.00	0.00	325.00	4.1000	1.00	81.61	334.61
Load 3	118.00	0.00	0.00	300.00	16.2000	1.00	81.43	1319.11

Unalaska Cargo Dock
 120' pole with 12 fixtures

Forces - Stresses - CSR

Elev Ft	Axial Force Lb	Shear Force Lb	Primary Moment Ft-Lb	Total Moment Ft-Lb	Axial Stress Psi	Bending Stress Psi	Total Stress Psi	Allow Stress Psi	Combined Stress Ratio
0.00	7518.	9405.	707438.	739728.	344.	59918.	60261.	65000.	0.93
5.00	7118.	9097.	661187.	693314.	334.	59144.	59478.	65000.	0.92
10.00	6749.	8800.	616449.	648111.	325.	58307.	58632.	65000.	0.90
14.00	6460.	8569.	581714.	612808.	318.	57587.	57905.	65000.	0.89
15.00	6389.	8511.	573174.	604102.	316.	57400.	57716.	65000.	0.89
20.00	6039.	8206.	531384.	561332.	307.	56417.	56724.	65000.	0.87
25.00	5699.	7890.	491147.	519901.	298.	55361.	55660.	65000.	0.86
29.00	5434.	7632.	460106.	487767.	291.	54464.	54755.	65000.	0.84
30.00	5368.	7568.	452506.	479877.	290.	54232.	54522.	65000.	0.84
35.00	5048.	7250.	415465.	441288.	281.	53026.	53306.	65000.	0.82
40.00	4737.	6938.	380000.	404138.	272.	51733.	52005.	65000.	0.80
44.64	4457.	6653.	348453.	370926.	264.	50448.	50712.	65000.	0.78
45.00	4415.	6631.	346081.	368423.	262.	50346.	50607.	65000.	0.78
48.44	4023.	6430.	323586.	344701.	238.	47025.	47263.	65000.	0.73
49.00	3990.	6396.	320025.	340946.	237.	46857.	47094.	65000.	0.72
50.00	3931.	6335.	313659.	334232.	235.	46552.	46788.	65000.	0.72
55.00	3643.	6037.	282733.	301537.	226.	44963.	45188.	65000.	0.70
60.00	3364.	5748.	253277.	270287.	216.	43252.	43467.	65000.	0.67
65.00	3095.	5470.	225237.	240451.	206.	41399.	41605.	65000.	0.64
70.00	2836.	5203.	198560.	211993.	196.	39380.	39576.	65000.	0.61
75.00	2587.	4947.	173190.	184877.	186.	37165.	37351.	65000.	0.57
80.00	2347.	4702.	149070.	159064.	176.	34716.	34891.	65000.	0.54
85.00	2117.	4464.	126159.	134527.	165.	31989.	32154.	65000.	0.49
86.61	2045.	4390.	119044.	126907.	162.	31045.	31207.	65000.	0.48
89.74	1806.	4243.	105536.	112474.	191.	36551.	36741.	65000.	0.57
90.00	1797.	4231.	104422.	111286.	190.	36334.	36524.	65000.	0.56
95.00	1633.	4002.	83844.	89338.	181.	31945.	32126.	65000.	0.49
100.00	1477.	3781.	64392.	68575.	171.	26972.	27143.	65000.	0.42
105.00	1328.	3568.	46025.	48975.	162.	21289.	21451.	65000.	0.33
110.00	1186.	3363.	28703.	30508.	152.	14734.	14887.	65000.	0.23
115.00	1052.	3166.	12386.	13145.	143.	7095.	7238.	65000.	0.11
118.00	975.	3053.	3058.	3243.	137.	1877.	2014.	65000.	0.03
119.00	650.	1696.	1343.	1403.	92.	831.	924.	65000.	0.01
120.00	300.	1325.	0.	0.	43.	0.	43.	65000.	0.00

Unalaska Cargo Dock
 120' pole with 12 fixtures

Carolina Highmast
PO Box 14069
Haltom City, TX 76117
(817) 834-3500
(817) 834-9700 fax

Deflection

Elevation Feet	Rotation Degrees	Deflection Feet
0.00	0.000	0.000
5.00	0.508	0.022
10.00	1.021	0.089
14.00	1.436	0.175
15.00	1.540	0.201
20.00	2.065	0.359
25.00	2.596	0.563
29.00	3.023	0.759
30.00	3.130	0.813
35.00	3.670	1.110
40.00	4.215	1.454
44.64	4.722	1.817
45.00	4.741	1.846
48.44	4.936	2.137
49.00	4.993	2.185
50.00	5.094	2.273
55.00	5.606	2.741
60.00	6.117	3.253
65.00	6.625	3.809
70.00	7.128	4.410
75.00	7.622	5.054
80.00	8.106	5.741
85.00	8.574	6.469
86.61	8.719	6.712
89.74	8.871	7.192
90.00	8.899	7.233
95.00	9.411	8.033
100.00	9.875	8.875
105.00	10.275	9.756
110.00	10.591	10.667
115.00	10.798	11.602
118.00	10.849	12.169
119.00	10.856	12.358
120.00	10.858	12.548

Unalaska Cargo Dock
120' pole with 12 fixtures

Carolina Highmast
PO Box 14069
Haltom City, TX 76117
(817) 834-3500
(817) 834-9700 fax

Thursday, January 27, 2000 21:08:41

Pole Attachment:

16 Side Polygonal Pole
Diameter Across Flats: 27.750 In
Attachment Angle: 0.000 Deg

Applied Loads:

Fx = 0.000 Lb
Fy = 9405.000 Lb
Fz = 7517.926 Lb
Mx = 739728.277 Ft-Lb
My = 0.000 Ft-Lb
Mz = 0.000 Ft-Lb

Specification: Whitco Standard

Unalaska Cargo Dock
Baseplate

Carolina Highmast
PO Box 14069
Haltom City, TX 76117
(817) 834-3500
(817) 834-9700 fax

Flange Description

Flange Shape: Round
Diameter: 36.000 In
Thickness: 1.75000 In
Yield Strength: 42000. Psi

Number of bolts: 16
Diameter: 1.25000 In
Bolt Circle: 32.000 In
First Bolt Angle: 0.000 Deg

Unalaska Cargo Dock
Baseplate

Carolina Highmast
PO Box 14069
Haltom City, TX 76117
(817) 834-3500
(817) 834-9700 fax

Flange Load Summary

Critical Wind Angle:	0.00	(Deg)
Maximum Stress Angle:	0.00	(Deg)
Failure Line Length:	22.9333	(In)
Flange Section Modulus:	11.7056	(In ³)
Moment About Failure Line:	22121.	(Ft-Lb)
Flange Bending Stress:	22677.	(Psi)
Allowable Bending Stress:	42000.	(Psi)
Combined Stress Ratio:	0.54	

Bolts Contributing To Maximum Moment

Bolt Number	Distance (In)	Load (Lb)
1	2.1250	-69819.
2	0.9071	-64540.
16	0.9071	-64540.

Unalaska Cargo Dock
Baseplate

Flange Section Detail

Mode Angle (Deg)	BendLine Length (In)	Section Modulus (In ³)	Calculated Moment (Ft-Lb)	Calculated Stress (Psi)
0.00	22.933	11.7056	265452.	22677.
2.50	22.671	11.5719	241255.	20848.
5.00	22.471	11.4697	216598.	18884.
7.50	22.336	11.4006	208318.	18273.
10.00	22.268	11.3658	207995.	18300.
12.50	22.268	11.3658	207276.	18237.
15.00	22.336	11.4006	206163.	18083.
17.50	22.471	11.4697	211064.	18402.
20.00	22.671	11.5719	228443.	19741.
22.50	22.933	11.7056	245387.	20963.
25.00	22.671	11.5719	217593.	18804.
27.50	22.471	11.4697	189386.	16512.
30.00	22.336	11.4006	178980.	15699.
32.50	22.268	11.3658	177270.	15597.
35.00	22.268	11.3658	175222.	15417.
37.50	22.336	11.4006	172842.	15161.
40.00	22.471	11.4697	173627.	15138.
42.50	22.671	11.5719	181109.	15651.
45.00	22.933	11.7056	188245.	16082.
47.50	22.671	11.5719	161061.	13918.
50.00	22.471	11.4697	133570.	11645.
52.50	22.336	11.4006	122614.	10755.
55.00	22.268	11.3658	119778.	10538.
57.50	22.268	11.3658	116714.	10269.
60.00	22.336	11.4006	113428.	9949.
62.50	22.471	11.4697	109986.	9589.
65.00	22.671	11.5719	106458.	9200.
67.50	22.933	11.7056	102727.	8776.
70.00	22.671	11.5719	80264.	6936.
72.50	22.471	11.4697	57649.	5026.
75.00	22.336	11.4006	47802.	4193.
77.50	22.268	11.3658	44272.	3895.
80.00	22.268	11.3658	40658.	3577.
82.50	22.336	11.4006	36966.	3242.
85.00	22.471	11.4697	36578.	3189.
87.50	22.671	11.5719	42902.	3707.
90.00	22.933	11.7056	49144.	4198.
92.50	22.671	11.5719	42400.	3664.
95.00	22.471	11.4697	35575.	3102.
97.50	22.336	11.4006	35708.	3132.
100.00	22.268	11.3658	39269.	3455.
102.50	22.268	11.3658	42756.	3762.
105.00	22.336	11.4006	46160.	4049.
107.50	22.471	11.4697	55764.	4862.
110.00	22.671	11.5719	77895.	6731.

Unalaska Cargo Dock
 Baseplate

Carolina Highmast
PO Box 14069
Haltom City, TX 76117
(817) 834-3500
(817) 834-9700 fax

112.50	22.933	11.7056	99877.	8532.
115.00	22.671	11.5719	103586.	8952.
117.50	22.471	11.4697	107098.	9337.
120.00	22.336	11.4006	110529.	9695.
122.50	22.268	11.3658	113809.	10013.
125.00	22.268	11.3658	116873.	10283.
127.50	22.336	11.4006	119715.	10501.
130.00	22.471	11.4697	130560.	11383.
132.50	22.671	11.5719	157702.	13628.
135.00	22.933	11.7056	184543.	15765.
137.50	22.671	11.5719	177750.	15360.
140.00	22.471	11.4697	170618.	14876.
142.50	22.336	11.4006	169943.	14906.
145.00	22.268	11.3658	172318.	15161.
147.50	22.268	11.3658	174365.	15341.
150.00	22.336	11.4006	176081.	15445.
152.50	22.471	11.4697	186376.	16249.
155.00	22.671	11.5719	214234.	18513.
157.50	22.933	11.7056	241685.	20647.
160.00	22.671	11.5719	225084.	19451.
162.50	22.471	11.4697	208055.	18140.
165.00	22.336	11.4006	203264.	17829.
167.50	22.268	11.3658	204372.	17981.
170.00	22.268	11.3658	205091.	18045.
172.50	22.336	11.4006	205419.	18018.
175.00	22.471	11.4697	213589.	18622.
177.50	22.671	11.5719	237896.	20558.
180.00	22.933	11.7056	261750.	22361.
182.50	22.671	11.5719	237896.	20558.
185.00	22.471	11.4697	213588.	18622.
187.50	22.336	11.4006	205419.	18018.
190.00	22.268	11.3658	205091.	18045.
192.50	22.268	11.3658	204372.	17981.
195.00	22.336	11.4006	203264.	17829.
197.50	22.471	11.4697	208055.	18140.
200.00	22.671	11.5719	225084.	19451.
202.50	22.933	11.7056	241685.	20647.
205.00	22.671	11.5719	214234.	18513.
207.50	22.471	11.4697	186376.	16249.
210.00	22.336	11.4006	176081.	15445.
212.50	22.268	11.3658	174365.	15341.
215.00	22.268	11.3658	172318.	15161.
217.50	22.336	11.4006	169943.	14906.
220.00	22.471	11.4697	170618.	14876.
222.50	22.671	11.5719	177750.	15360.
225.00	22.933	11.7056	184543.	15765.
227.50	22.671	11.5719	157702.	13628.
230.00	22.471	11.4697	130560.	11383.
232.50	22.336	11.4006	119715.	10501.
235.00	22.268	11.3658	116873.	10283.

Unalaska Cargo Dock
Baseplate

Carolina Highmast
 PO Box 14069
 Haltom City, TX 76117
 (817) 834-3500
 (817) 834-9700 fax

237.50	22.268	11.3658	113809.	10013.
240.00	22.336	11.4006	110529.	9695.
242.50	22.471	11.4697	107098.	9337.
245.00	22.671	11.5719	103586.	8952.
247.50	22.933	11.7056	99877.	8532.
250.00	22.671	11.5719	77895.	6731.
252.50	22.471	11.4697	55764.	4862.
255.00	22.336	11.4006	46160.	4049.
257.50	22.268	11.3658	42756.	3762.
260.00	22.268	11.3658	39269.	3455.
262.50	22.336	11.4006	35708.	3132.
265.00	22.471	11.4697	35575.	3102.
267.50	22.671	11.5719	42400.	3664.
270.00	22.933	11.7056	49144.	4198.
272.50	22.671	11.5719	42902.	3707.
275.00	22.471	11.4697	36578.	3189.
277.50	22.336	11.4006	36966.	3242.
280.00	22.268	11.3658	40658.	3577.
282.50	22.268	11.3658	44272.	3895.
285.00	22.336	11.4006	47802.	4193.
287.50	22.471	11.4697	57649.	5026.
290.00	22.671	11.5719	80264.	6936.
292.50	22.933	11.7056	102727.	8776.
295.00	22.671	11.5719	106458.	9200.
297.50	22.471	11.4697	109986.	9589.
300.00	22.336	11.4006	113428.	9949.
302.50	22.268	11.3658	116714.	10269.
305.00	22.268	11.3658	119778.	10538.
307.50	22.336	11.4006	122614.	10755.
310.00	22.471	11.4697	133570.	11645.
312.50	22.671	11.5719	161061.	13918.
315.00	22.933	11.7056	188245.	16082.
317.50	22.671	11.5719	181109.	15651.
320.00	22.471	11.4697	173627.	15138.
322.50	22.336	11.4006	172842.	15161.
325.00	22.268	11.3658	175222.	15417.
327.50	22.268	11.3658	177270.	15597.
330.00	22.336	11.4006	178980.	15699.
332.50	22.471	11.4697	189386.	16512.
335.00	22.671	11.5719	217593.	18804.
337.50	22.933	11.7056	245387.	20963.
340.00	22.671	11.5719	228443.	19741.
342.50	22.471	11.4697	211064.	18402.
345.00	22.336	11.4006	206163.	18083.
347.50	22.268	11.3658	207276.	18237.
350.00	22.268	11.3658	207995.	18300.
352.50	22.336	11.4006	208318.	18273.
355.00	22.471	11.4697	216598.	18884.
357.50	22.671	11.5719	241255.	20848.

Unalaska Cargo Dock
 Baseplate

Carolina Highmast
PO Box 14069
Haltom City, TX 76117
(817) 834-3500
(817) 834-9700 fax

Bolt Description

Number of bolts:	16	
Major Diameter:	1.25000	In
Length:	15.000	In
Yield Strength:	81000.	Psi
Root Diameter:	1.07500	In
Gross Area:	1.22700	In ²
Root Area:	0.89000	In ²
Tensile Stress Area:	0.96900	In ²
Threads per Inch:	7.00000	
Pitch:	0.14290	In

Unalaska Cargo Dock
Baseplate

Carolina Highmast
 PO Box 14069
 Haltom City, TX 76117
 (817) 834-3500
 (817) 834-9700 fax

Bolt Force and Stress Summary

Wind angle resulting in maximum Bolt CSR: 0.00 Deg

Bolt Number	Calculated Force		Calculated Stress		Allowable Stress		Combined Stress Ratio
	Axial (Lb)	Shear (Lb)	Axial (Psi)	Shear (Psi)	Axial (Psi)	Shear (Psi)	
1	-69819.	588.	72053.	607.	81000.	52650.	0.89
2	-64540.	588.	66605.	607.	81000.	52650.	0.82
3	-49507.	588.	51091.	607.	81000.	52650.	0.63
4	-27009.	588.	27873.	607.	81000.	52650.	0.34
5	-470.	588.	485.	607.	81000.	52650.	0.01
6	26069.	588.	26903.	607.	81000.	52650.	0.33
7	48568.	588.	50121.	607.	81000.	52650.	0.62
8	63601.	588.	65635.	607.	81000.	52650.	0.81
9	68880.	588.	71083.	607.	81000.	52650.	0.88
10	63601.	588.	65635.	607.	81000.	52650.	0.81
11	48568.	588.	50121.	607.	81000.	52650.	0.62
12	26069.	588.	26903.	607.	81000.	52650.	0.33
13	-470.	588.	485.	607.	81000.	52650.	0.01
14	-27009.	588.	27873.	607.	81000.	52650.	0.34
15	-49507.	588.	51091.	607.	81000.	52650.	0.63
16	-64540.	588.	66605.	607.	81000.	52650.	0.82

DETAIL 2

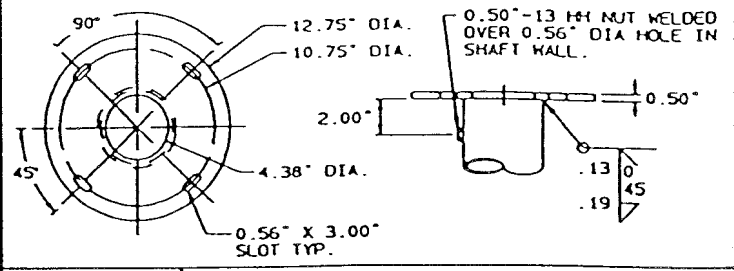
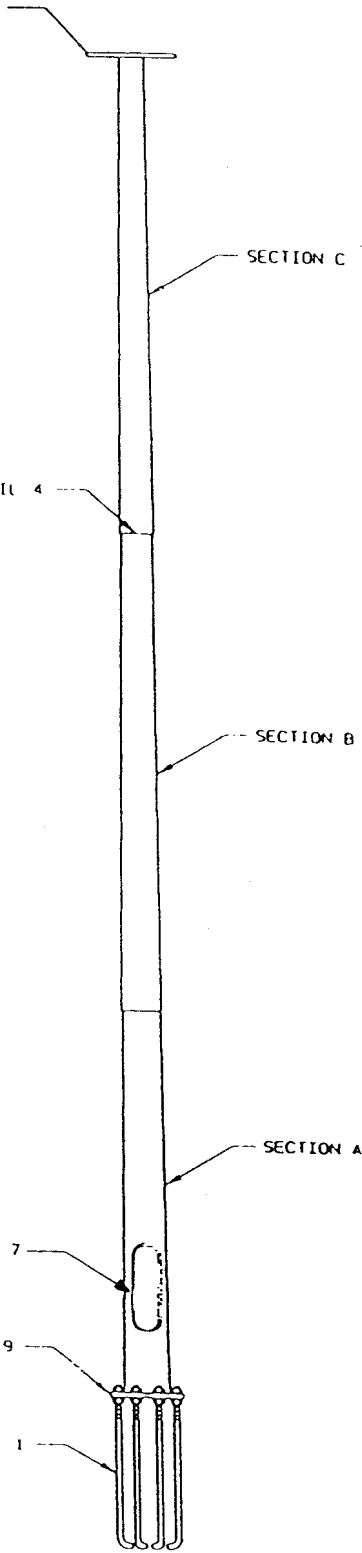

DETAIL 2

POLE TOP

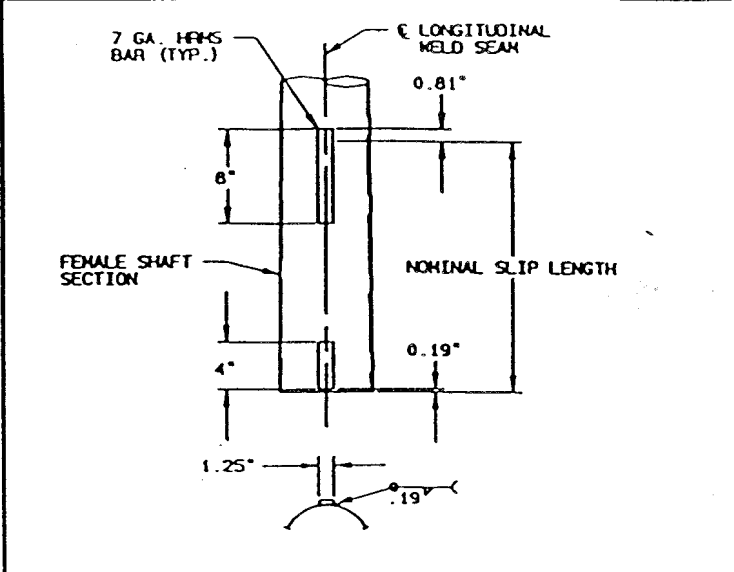

DETAIL 3

WELD REINFORCEMENT

EACH ANCHOR BOLT PROVIDED WITH (2) HEX NUTS AND (2) WASHERS PER BOLT WITH THREADED END GALVANIZED AT LEAST 12".

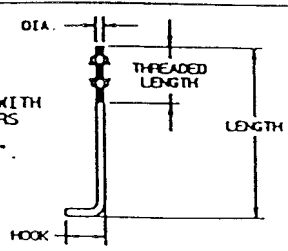

DETAIL 1

ANCHOR BOLT

MATERIAL DATA

COMPONENT	ASTM DESIGNATION	MIN. YIELD (KSI)
SHAFT 11, 7 & 3 GA.	A595 GR. A	55
BASE PLATE 11, 7 & 3 GA.	A36	36
SHAFT - ALL OTHERS	A572	65
BASE PLATE - ALL OTHERS	A572	42
POLE TOP PLATE	A572	42
ANCHOR BOLTS	F1554 GR. 55	55
GALVANIZING	A123 & A153	--
SUPPORT PLATES	A36	36
HANDHOLE RIM	A588	50
HANDHOLE COVER	A36	36
HANDHOLE HINGE	A595 GR. A	55

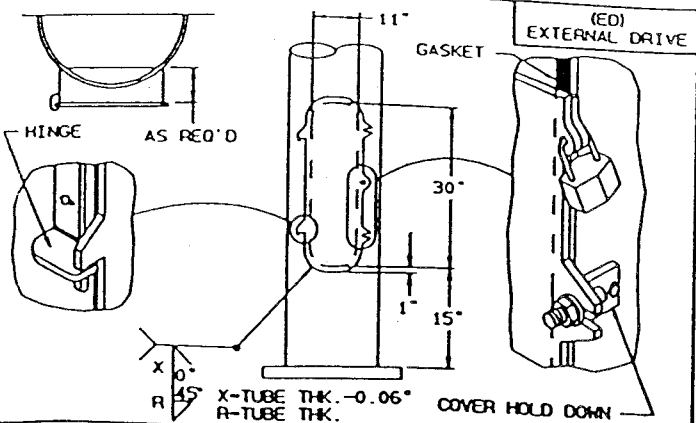

THE HANDHOLE COVER SHALL BE MANUFACTURED FROM 0.25" THICK STEEL. SEALED WITH NEOPRENE RUBBER GASKET AND FEATURES COVER PULL DOWNS TO INSURE WEATHER-TIGHT PROTECTION. COVER MAY ALSO BE LOCKED WITH THE USE OF A PAD-LOCK (NOT PROVIDED). HINGE MANUFACTURED FROM 7 GA. STEEL AND OFFERS ADJUSTABILITY OF COVER FOR WEATHER-TIGHT FIT. COMPONENTS SHALL BE FASTENED TO THE RIM WITH 0.25"-20 UNC STAINLESS STEEL CARRIAGE BOLTS FOR TAMPER RESISTANT ATTACHMENT.

DETAIL 6 11" X 30" HINGED AND LOCKABLE HANDHOLE

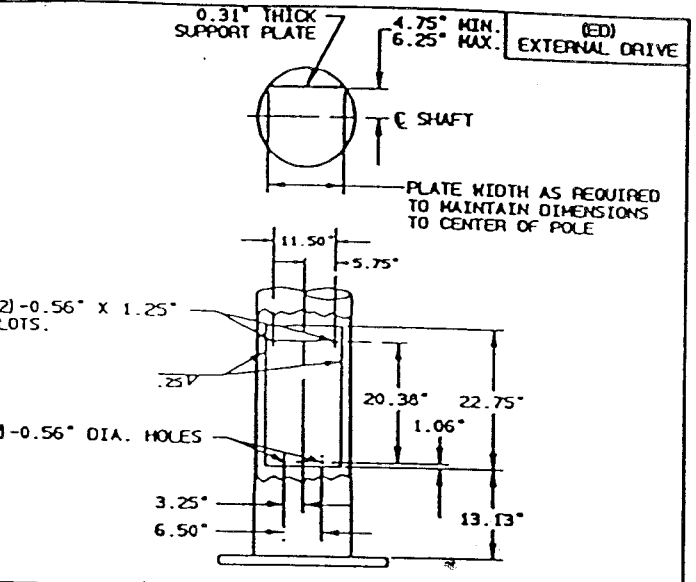

DETAIL 7 SUPPORT PLATE - OPTIONAL

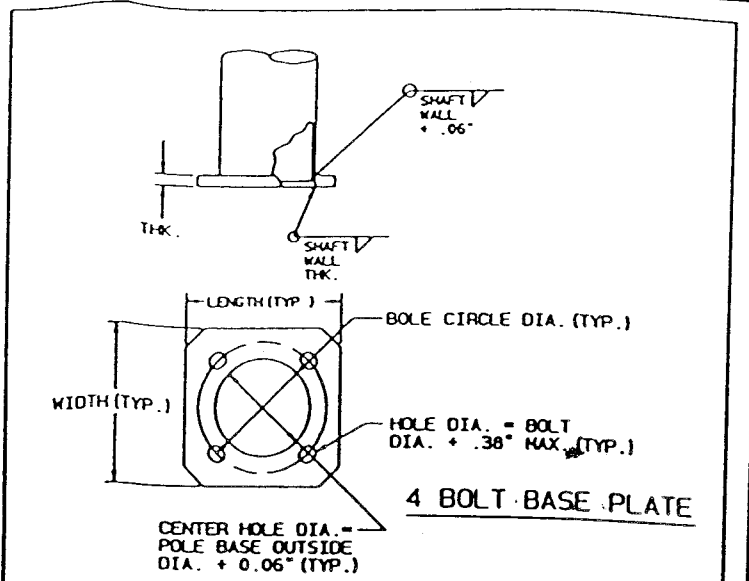

DETAIL 8 BASEPLATES

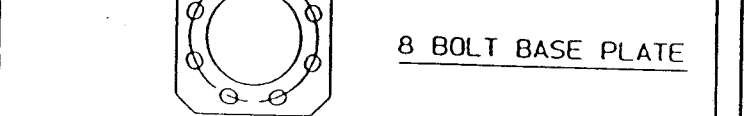
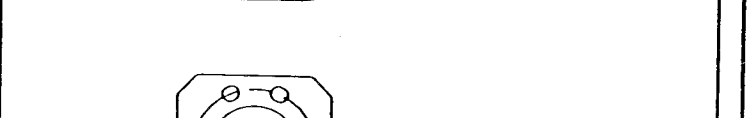
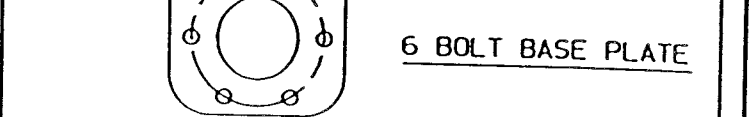

DETAIL 9 TIE OFF LOOPS

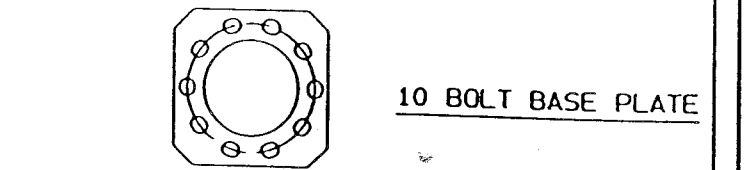

DETAIL 9 TIE OFF LOOPS

REV	DATE	REVISION
0	04/22/98	REV. FOR GREATER ACCURACY JLE/DLE
JOB NAME		
SOLD TO		
SHIP TO		
P.O. NO.		
AGENT		
DATE: 01/06/98	DRWN: TJK	
TITLE		

VALMONT.
VALMONT INDUSTRIES, INC.
VALLEY, NEBRASKA 68064
(402) 359-2201

ORDER NO.:
SHEET 1 OF 6
DRAWING NO.
DB00504

REV. A

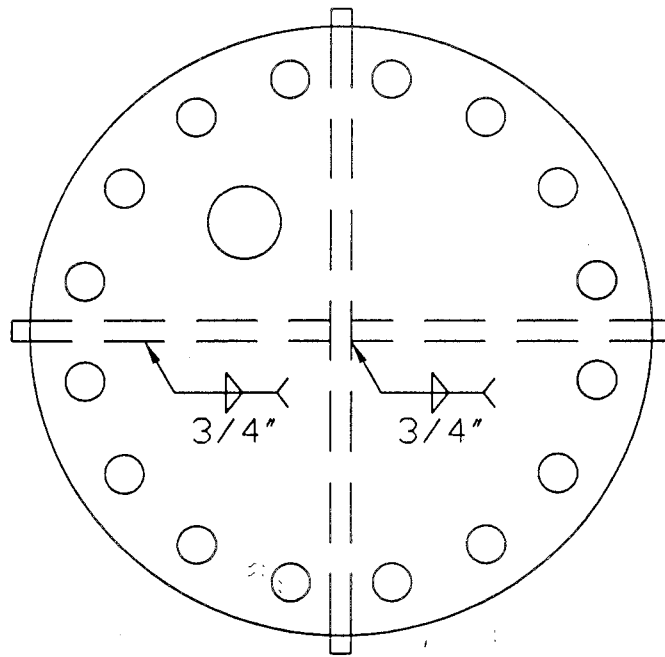

CAP PLATE

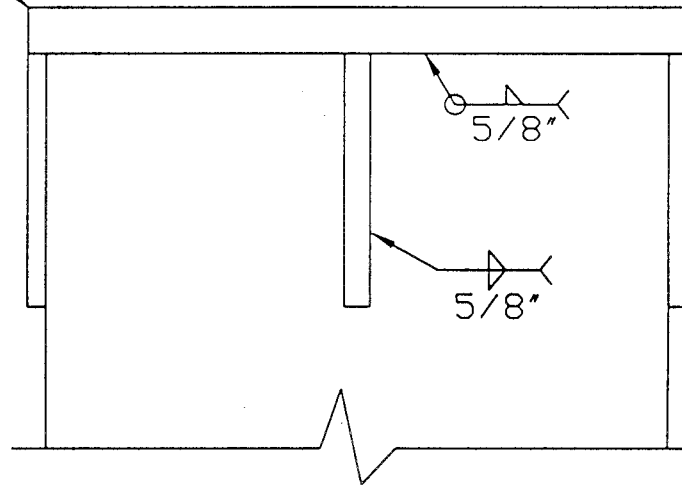

KNIFE PLATE (QTY. 2)

ROLINA HIGH MAST

Checked by:

Drawn by:
MRS

CAP PLATE
ASSEMBLY
ANCHORAGE ALASKA

Date:

1-7

Draw
ASSL

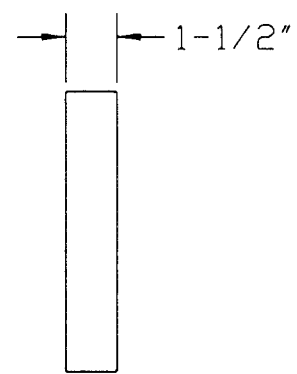
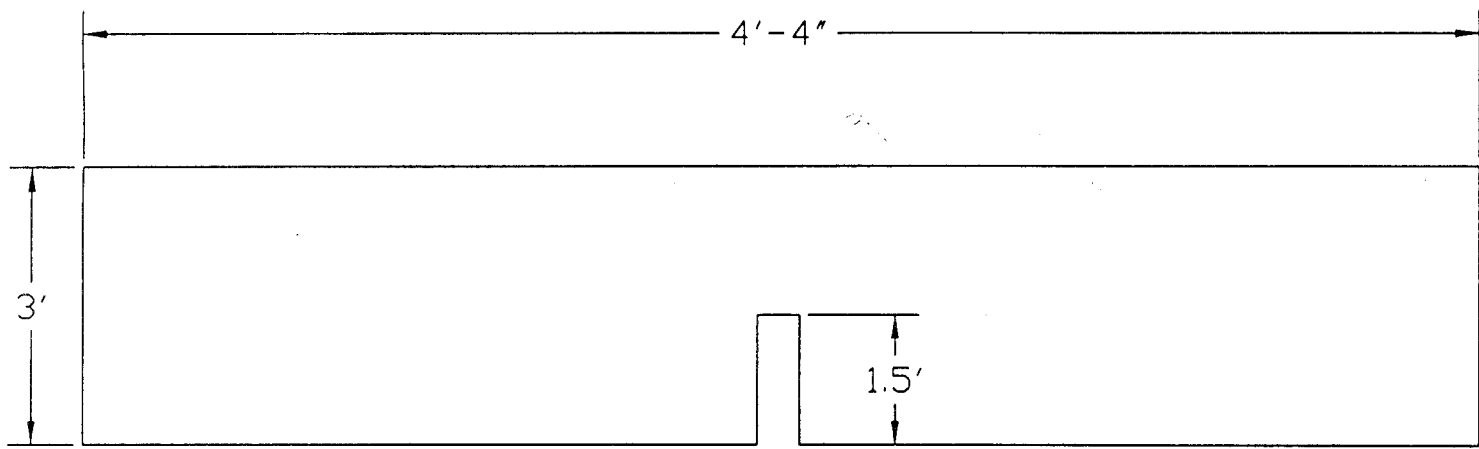

ROLINA HIGH MAST

Checked by:
Drawn by:
MRS

KNIFE
PLATE (QTY. 2)
ANCHORAGE ALASKA

Date:
1-28-90
Drc
KN

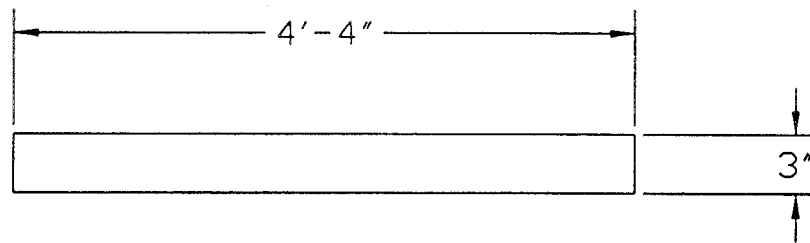
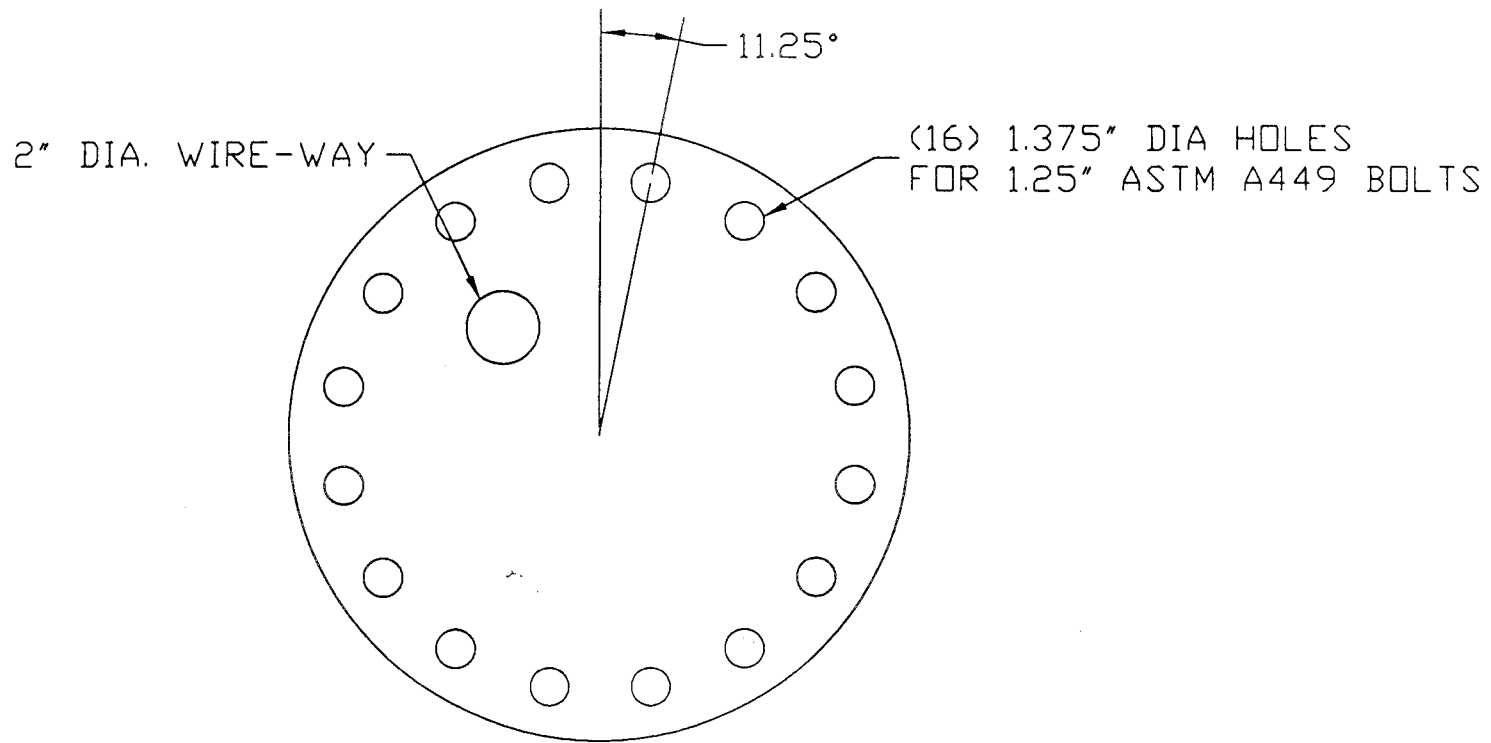

AROLINA HIGH MAST

Checked by:

Drawn by:
MRS

CAP
PLATE
ANCHORAGE ALASKA

Date:

1-25-20

Drawn by:
CAF

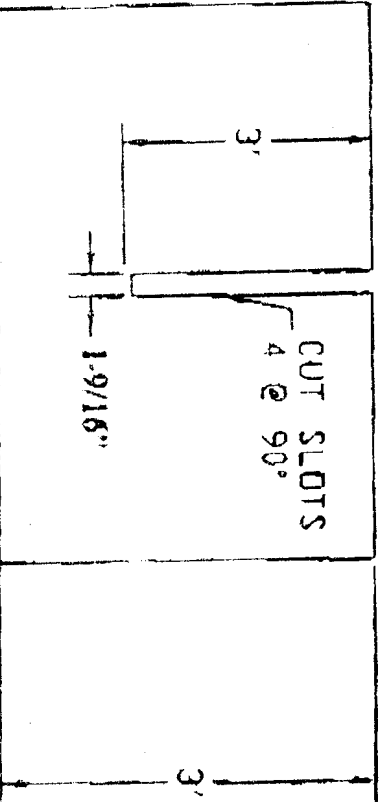
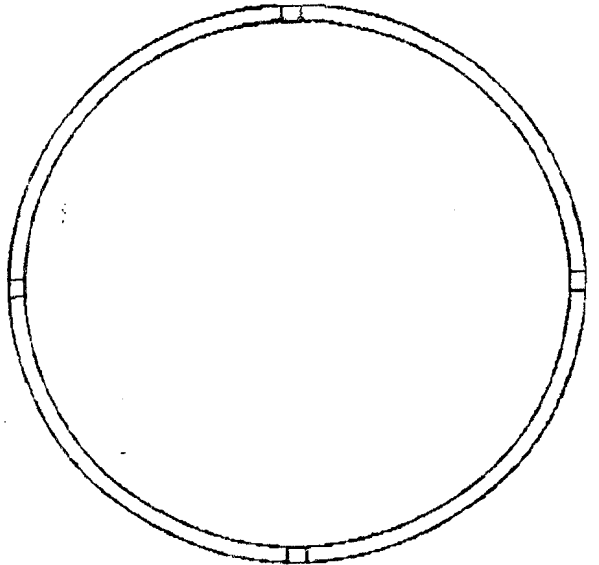

CAROLINA HIGH MAST

Checked by:
 Drawn by:
 QS

EXISTING
 PILE
 ANCHORAGE ALASKA

Detail:
 1-28-00
 Drawing Number:
 STUB